



SBC BL2600

C-Programmable Single-Board Computer with Ethernet

User's Manual

019-0142_L

SBC BL2600 User's Manual

©2011 Digi International® Inc.

All rights reserved.

Rabbit, Dynamic C, RabbitCore, RabbitNet, Digi, Digi International, Digi International Company, and the Digi and Rabbit logos are trademarks or registered trademarks of Digi International, Inc. in the United States and other countries worldwide. All other trademarks are the property of their respective owners.

Information in this document is subject to change without notice and does not represent a commitment on the part of Digi International.

Digi provides this document "as is," without warranty of any kind, expressed or implied, including, but not limited to, the implied warranties of fitness or merchantability for a particular purpose. Digi may make improvements and/or changes in this manual or in the product(s) and/or the program(s) described in this manual at any time.

This product could include technical inaccuracies or typographical errors. Changes are periodically made to the information herein; these changes may be incorporated in new editions of the publication.

The latest revision of this manual is available at www.digi.com.

TABLE OF CONTENTS

Chapter 1. Introduction	1
1.1 BL2600 Description.....	1
1.2 BL2600 Features.....	1
1.2.1 Connector Options	3
1.2.2 Memory and Clock Speed Options	3
1.3 Development and Evaluation Tools.....	4
1.3.1 Tool Kit.....	4
1.3.2 Software	5
1.3.3 Additional Tools	5
1.4 CE Compliance	6
1.4.1 Design Guidelines	7
1.4.2 Interfacing the BL2600 to Other Devices	7
Chapter 2. Getting Started	9
2.1 Preparing the BL2600 for Development.....	9
2.2 BL2600 Connections	10
2.2.1 Hardware Reset.....	11
2.3 Installing Dynamic C.....	12
2.4 Starting Dynamic C	13
2.5 PONG.C.....	14
2.6 Where Do I Go From Here?	14
Chapter 3. Subsystems	15
3.1 BL2600 Pinouts	16
3.1.1 Connector Options	18
3.2 Digital I/O	19
3.2.1 Digital Inputs.....	19
3.2.2 PWM Outputs	20
3.2.3 High-Current Digital Outputs	21
3.2.4 Configurable I/O	23
3.3 Serial Communication	25
3.3.1 RS-232	25
3.3.2 RS-485	25
3.3.3 Programming Port.....	27
3.3.4 Ethernet Port	28
3.4 A/D Converter Inputs.....	29
3.4.1 A/D Converter Calibration.....	30
3.5 D/A Converter Outputs	31
3.5.1 D/A Converter Calibration.....	32
3.6 Analog Reference Voltage Circuit.....	33
3.7 Serial Programming Cable.....	34
3.7.1 Changing Between Program Mode and Run Mode	34
3.8 Other Hardware.....	35
3.8.1 Clock Doubler	35
3.8.2 Spectrum Spreader	35

3.9 Memory	36
3.9.1 SRAM.....	36
3.9.2 Flash Memory.....	36
3.9.3 Serial Flash.....	36
3.9.4 NAND Flash.....	37
Chapter 4. Software	39
4.1 Running Dynamic C.....	39
4.1.1 Upgrading Dynamic C.....	41
4.2 Sample Programs.....	42
4.2.1 General BL2600 Sample Programs.....	42
4.2.2 Digital I/O.....	42
4.2.3 Serial Communication.....	43
4.2.4 A/D Converter Inputs.....	44
4.2.5 D/A Converter Outputs.....	45
4.2.6 Use of BL2600 with SF1000 Serial Flash Card.....	46
4.2.7 Use of NAND Flash.....	46
4.2.8 Real-Time Clock.....	47
4.2.9 TCP/IP Sample Programs.....	47
4.3 BL2600 Libraries.....	47
4.4 BL2600 Function Calls.....	48
4.4.1 Board Initialization.....	48
4.4.2 Digital I/O.....	49
4.4.3 Serial Communication.....	57
4.4.4 A/D Converter Inputs.....	59
4.4.5 D/A Converter Outputs.....	66
4.4.6 SRAM Use.....	70
4.4.7 NAND Flash Drivers.....	70
Chapter 5. Using the TCP/IP Features	71
5.1 TCP/IP Connections.....	71
5.2 TCP/IP Sample Programs.....	73
5.2.1 How to Set IP Addresses in the Sample Programs.....	73
5.2.2 How to Set Up your Computer's IP Address for a Direct Connection.....	74
5.2.3 Run the PINGME.C Demo.....	75
5.2.4 Running More Demo Programs With a Direct Connection.....	76
5.3 Where Do I Go From Here?.....	76
Appendix A. Specifications	77
A.1 Electrical and Mechanical Specifications.....	78
A.1.1 Exclusion Zone.....	80
A.1.2 Headers.....	81
A.2 Conformal Coating.....	82
A.3 Jumper Configurations.....	83
A.4 Use of Rabbit 3000 Parallel Ports.....	85
Appendix B. Power Supply	87
B.1 Power Supplies.....	87
B.1.1 Power for Analog Circuits.....	88
B.2 Batteries and External Battery Connections.....	88
B.2.1 Replacing the Backup Battery.....	88
B.3 Power to Peripheral Boards.....	89
Appendix C.	
Demonstration Board	91

C.1 Connecting Demonstration Board.....	91
Appendix D. RabbitNet	95
D.1 General RabbitNet Description.....	95
D.1.1 RabbitNet Connections	95
D.1.2 RabbitNet Peripheral Cards.....	96
D.2 Physical Implementation.....	97
D.2.1 Control and Routing.....	97
D.3 Function Calls	98
D.3.1 Status Byte	104
Schematics	105
Index	107

1. INTRODUCTION

The BL2600 is a high-performance, C-programmable single-board computer that offers built-in digital and analog I/O combined with Ethernet connectivity in a compact form factor. The BL2600 is ideal for both discrete manufacturing and process-control applications.

A Rabbit® 3000 microprocessor operating at up to 44.2 MHz provides fast data processing with 10/100Base-T Ethernet connectivity. Serial flash options support a full directory file structures to maximize remote access control and programmability. The I/O can be expanded with RabbitNet peripheral cards.

1.1 BL2600 Description

Throughout this manual, the term BL2600 refers to the complete series of BL2600 single-board computers unless other production models are referred to specifically.

The BL2600 is an advanced single-board computer that incorporates the powerful Rabbit 3000 microprocessor, flash memory, serial flash options, static RAM, digital I/O ports, A/D converter inputs, D/A converter outputs, RS-232/RS-485 serial ports, and a 10/100Base-T Ethernet port.

1.2 BL2600 Features

- Rabbit® 3000 microprocessor operating at 29.4 MHz or 44.2 MHz.
- Dual-entry IDC through-hole I/O header sockets allow header mounting on either side of the BL2600 board
- Industry-standard friction-lock connectors for power-supply wiring harness.
- 512K static RAM and 512K flash memory standard.
- 36 digital I/O: 16 protected digital inputs, 4 high-current digital outputs software-configurable as sinking or sourcing, and 16 I/O individually software-configurable as inputs or sinking outputs.
- 12 analog channels: eight 11-bit A/D converter inputs, four 12-bit D/A converter 0–10 V or ± 10 V buffered outputs.

- One RJ-45 Ethernet port compliant with IEEE 802.3 standard for 10/100Base-T Ethernet protocol.
- Up to 5 serial ports:
 - ▶ Three serial ports (2 RS-232 or 1 RS-232 with RTS/CTS, 1 RS-485 or RS-232).
 - ▶ Two RabbitNet™ expansion ports multiplexed from one serial port.
 - ▶ One serial port dedicated to programming/debugging.
- Provision to install optional SF1000 serial flash, other memory options have provision for removable memory cards.
- Battery-backed real-time clock.
- Watchdog supervisor.

Two BL2600 models are available. Their standard features are summarized in Table 1.

Table 1. BL2600 Models

Feature	BL2600	BL2610
Microprocessor	Rabbit® 3000 running at 44.2 MHz	Rabbit® 3000 running at 29.4 MHz
Program Execution SRAM	512K	—
Data SRAM	256K	512K
Flash Memory	512K	
Ethernet Port	10/100Base-T, 3 LEDs	—
RabbitCore Module Used	RCM3200	RCM3100

Additional memory and clock speed options are available, and are described in Section 1.2.2.

The BL2600 consists of a main board with a RabbitCore module. Refer to the RabbitCore module manuals, available on the [Web site](#), for more information on the RabbitCore modules, including their schematics.



The BL2600 is programmed over a standard PC serial port through a programming cable supplied with the Tool Kit, and can also be programmed through a USB port with an RS-232/USB converter, or over an Ethernet with the RabbitLink (both available from Rabbit).

Appendix A provides detailed specifications.

Visit the [Web site](#) for up-to-date information about additional add-ons and features as they become available. The Web site also has the latest revision of this user's manual.

1.2.1 Connector Options

In addition to the standard polarized friction-lock connectors supplied on BL2600 boards, dual-entry 0.1" IDC sockets can be used to connect to the BL2600 either from the top or the bottom.

Standard polarized friction-lock terminals, 0.1" pitch		0.1" IDC sockets can accept header pins from either top or bottom	
--	---	---	---

1.2.2 Memory and Clock Speed Options

In addition to the two standard production models of the BL2600, the concept of pairing a RabbitCore module with the BL2600 “motherboard” allows for additional versions of the BL2600 to be offered for custom orders involving nominal lead times. These additional versions and their part numbers are listed below.

Table 2. Additional BL2600 Memory, Clock Speed, and Ethernet Options

Feature	101-0906	101-0907	101-0908	101-1095	101-1096
Clock Speed	29.4 MHz	29.4 MHz	29.4 MHz	44.2 MHz	44.2 MHz
Program Execution SRAM	—	—	—	512K	512K
Data SRAM	512K	128K	128K	512K	512K
Flash Memory (program)	512K	256K	256K	512K	512K
NAND Flash Memory (mass data storage, fixed)	—	—	—	16 Mbytes	—
NAND Flash Memory (mass data storage, removable memory card)				up to 128 Mbytes	
Ethernet Port	10/100-compatible 10Base-T interface		—	10/100Base-T	
RabbitCore Module Used	RCM3000	RCM3010	RCM3110	RCM3365	RCM3375

Check the [Web site](#) or contact your Digi sales representative or authorized distributor for more information.

1.3 Development and Evaluation Tools

1.3.1 Tool Kit

A Tool Kit contains the hardware essentials you will need to use your own BL2600 single-board computer. The items in the Tool Kit and their use are as follows.

- *Getting Started* instructions.
- *Dynamic C* CD-ROM, with complete product documentation on disk.
- Programming cable, used to connect your PC serial port to the BL2600.
- Universal AC adapter, 12 V DC, 1 A (includes Canada/Japan/U.S., Australia/N.Z., U.K., and European style plugs). If you are using another power supply, it must provide 9 to 36 V DC at 12 W.
- Stand-offs to serve as legs for the BL2600 board during development.
- Demonstration Board with pushbutton switches and LEDs. The Demonstration Board can be hooked up to the BL2600 to demonstrate the I/O and the TCP/IP capabilities of the BL2600.
- Wire assembly to connect Demonstration Board to BL2600.
- Connector pins and parts to build your own wire assemblies: 0.1" crimp terminals; 0.156" crimp terminals; 1 × 4, 1 × 10, and 1 × 13 friction-lock connectors.
- *Rabbit 3000 Processor Easy Reference* poster.
- Registration card.

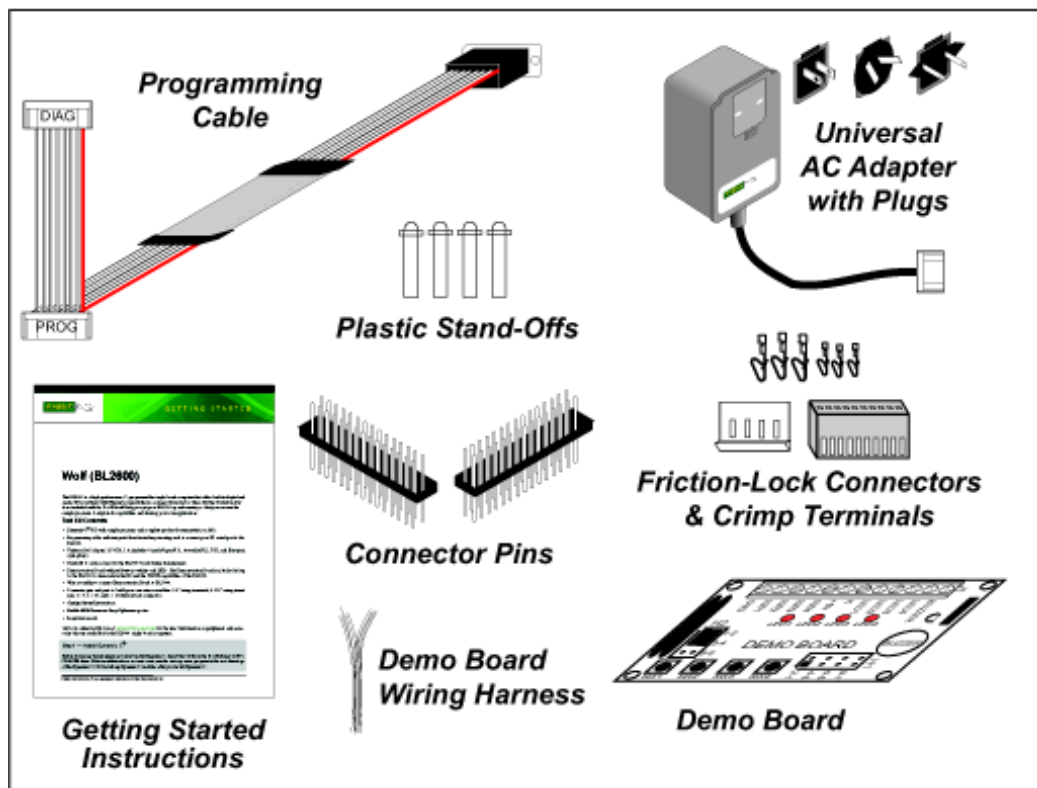

Figure 1. BL2600 Tool Kit

1.3.2 Software

The BL2600 is programmed using version 8.51 or later of Rabbit's Dynamic C. A compatible version is included on the Tool Kit CD-ROM.

Digi also offers add-on Dynamic C modules for purchase containing the popular μ C/OS-II real-time operating system, as well as PPP, Advanced Encryption Standard (AES), and other select libraries. In addition to the Web-based technical support included at no extra charge, a one-year telephone-based technical support module is also available for purchase. Visit our Web site at www.digi.com or contact your Digi sales representative or authorized distributor for further information.

1.3.3 Additional Tools

Rabbit also has available additional programming tools and parts to help you to make your own wiring assemblies with the friction-lock connectors.

- An RS-232/USB converter cable (Part No. 540-0070) is available for use with the programming cable supplied with the Tool Kit. You will need such a converter if your PC only has a USB port.
- Crimp tool (Part No. 998-0013) to secure wire in crimp terminals.

Visit our Web site at www.digi.com or contact your Digi sales representative or authorized distributor for further information.

1.4 CE Compliance

Equipment is generally divided into two classes.

CLASS A	CLASS B
Digital equipment meant for light industrial use	Digital equipment meant for home use
Less restrictive emissions requirement: less than 40 dB $\mu\text{V}/\text{m}$ at 10 m (40 dB relative to 1 $\mu\text{V}/\text{m}$) or 300 $\mu\text{V}/\text{m}$	More restrictive emissions requirement: 30 dB $\mu\text{V}/\text{m}$ at 10 m or 100 $\mu\text{V}/\text{m}$

These limits apply over the range of 30–230 MHz. The limits are 7 dB higher for frequencies above 230 MHz. Although the test range goes to 1 GHz, the emissions from Rabbit-based systems at frequencies above 300 MHz are generally well below background noise levels.

The BL2600 single-board computer has been tested and was found to be in conformity with the following applicable immunity and emission standards. The BL2610 single-board computer is also CE qualified as it is a sub-version of the BL2600 single-board computer. Boards that are CE-compliant have the CE mark.



NOTE: Earlier versions of the BL2600 that do not have the CE mark are *not* CE-compliant.

Immunity

The BL2600 series of single-board computers meets the following EN55024/1998 immunity standards.

- EN61000-4-3 (Radiated Immunity)
- EN61000-4-4 (EFT)
- EN61000-4-6 (Conducted Immunity)

Additional shielding or filtering may be required for a heavy industrial environment.

Emissions

The BL2600 series of single-board computers meets the following emission standards.

- EN55022:1998 Class B
- FCC Part 15 Class B

Your results may vary, depending on your application, so additional shielding or filtering may be needed to maintain the Class B emission qualification.

1.4.1 Design Guidelines

Note the following requirements for incorporating the BL2600 series of single-board computers into your application to comply with CE requirements.

General

- The power supply provided with the Tool Kit is for development purposes only. It is the customer's responsibility to provide a CE-compliant power supply for the end-product application.
- When connecting the BL2600 single-board computer to outdoor cables, the customer is responsible for providing CE-approved surge/lightning protection.
- Rabbit recommends placing digital I/O or analog cables that are 3 m or longer in a metal conduit to assist in maintaining CE compliance and to conform to good cable design practices.
- When installing or servicing the BL2600, it is the responsibility of the end-user to use proper ESD precautions to prevent ESD damage to the BL2600.

Safety

- All inputs and outputs to and from the BL2600 series of single-board computers must not be connected to voltages exceeding SELV levels (42.4 V AC peak, or 60 V DC).
- The lithium backup battery circuit on the BL2600 single-board computer has been designed to protect the battery from hazardous conditions such as reverse charging and excessive current flows. Do not disable the safety features of the design.

1.4.2 Interfacing the BL2600 to Other Devices

Since the BL2600 series of single-board computers is designed to be connected to other devices, good EMC practices should be followed to ensure compliance. CE compliance is ultimately the responsibility of the integrator. Additional information, tips, and technical assistance are available from your authorized Rabbit distributor, and are also available on our Web site at www.digi.com.

2. GETTING STARTED

Chapter 2 explains how to connect the programming cable and power supply to the BL2600.

2.1 Preparing the BL2600 for Development

Position the BL2600 as shown below in Figure 2. Attach the four standoffs supplied with the Tool Kit in the holes at the corners as shown.

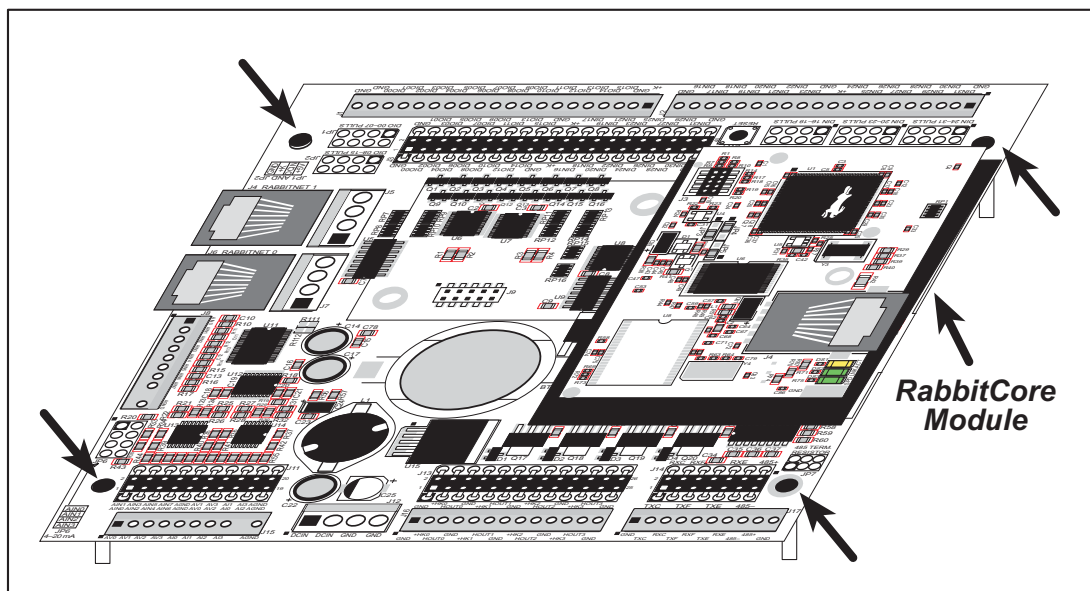

Figure 2. Attach Standoffs to BL2600 Board

The standoffs facilitate handling the BL2600 during development, and protect the bottom of the printed circuit board against scratches or short circuits while you are working with the BL2600.

2.2 BL2600 Connections

1. Connect the programming cable to download programs from your PC and to program and debug the BL2600.

NOTE: Use only the programming cable that has a blue shrink wrap around the RS-232 level converter (Part No. 101-0542). If you are using a BL2610, which is based on the RCM3100, you will need the programming cable that has a red shrink wrap around the RS-232 level converter (Part No. 101-0513). Other programming cables are not voltage-compatible or their connector sizes may be different.

Connect the 10-pin **PROG** connector of the programming cable to header J3 on the BL2600's RabbitCore module (the programming header is labeled J1 on special-edition BL2600s based on the RCM3365/RCM3375). Ensure that the colored edge lines up with pin 1 as shown. (Do not use the **DIAG** connector, which is used for monitoring only.) Connect the other end of the programming cable to a COM port on your PC. Make a note of the port to which you connect the cable, as Dynamic C will need to have this parameter configured. Note that COM1 on the PC is the default COM port used by Dynamic C.

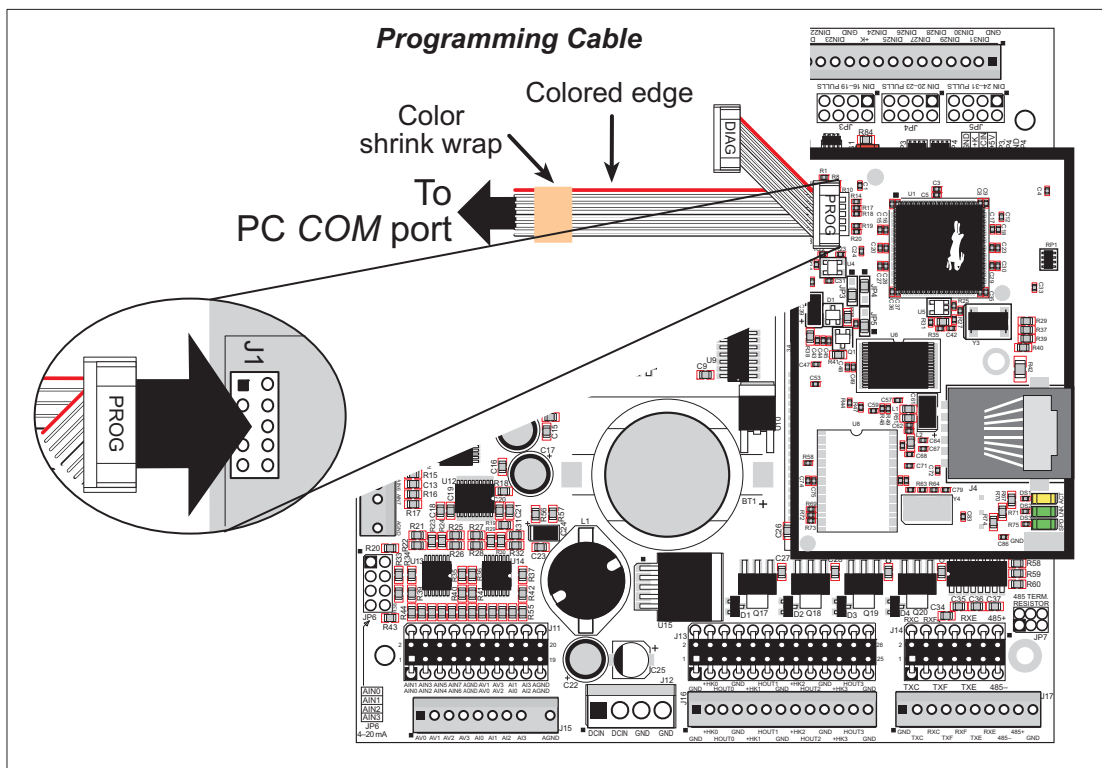

2. When all other connections have been made, you can connect power to the BL2600.

First, prepare the AC adapter for the country where it will be used by selecting the plug. The BL2600 Tool Kit presently includes Canada/Japan/U.S., Australia/N.Z., U.K., and European style plugs. Snap in the top of the plug assembly into the slot at the top of the AC adapter as shown in Figure 4, then press down on the spring-loaded clip below the plug assembly to allow the plug assembly to click into place.

Connect the AC adapter to header J12 on the BL2600 as shown in Figure 4. You can use the crimps and the friction-lock connector included in the Tool Kit to connect the leads from the power supply, then match the friction lock tab on the friction-lock connector to the back of header J12 on the BL2600 as shown. The friction-lock connector will only fit one way.

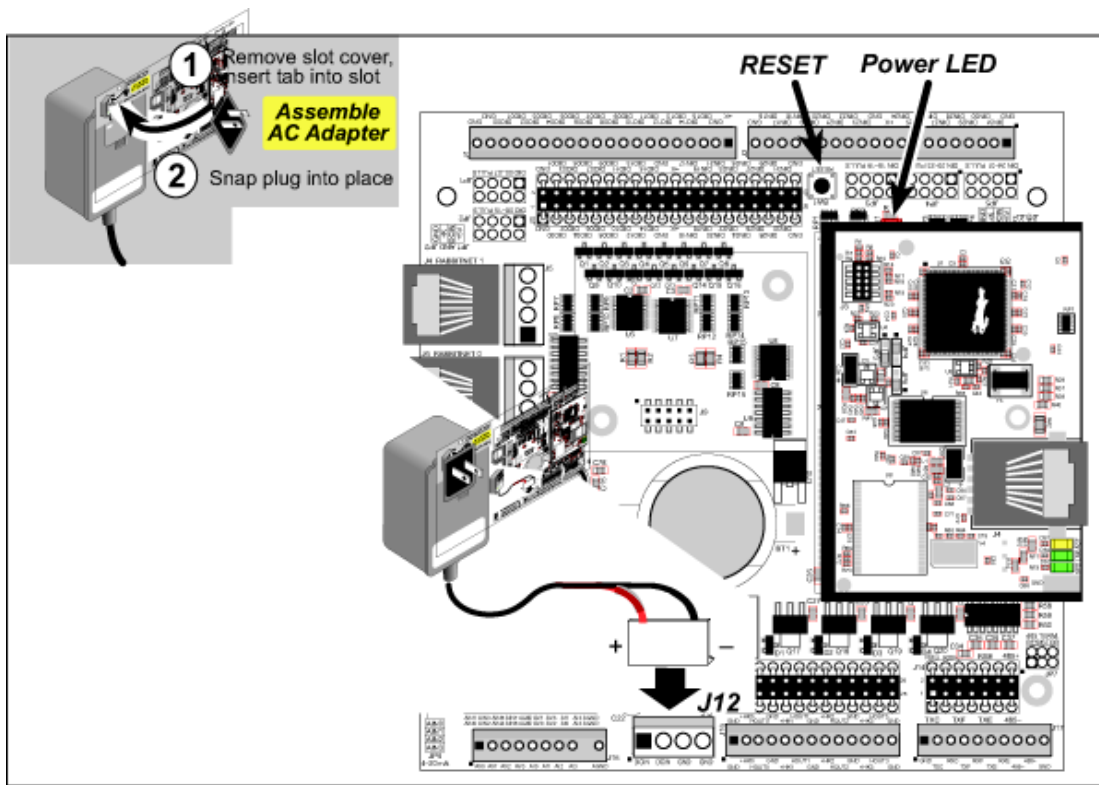

Figure 4. Power Supply Connections

3. Apply power.

Plug in the AC adapter. The power LED will light up when the BL2600 is powered up correctly.

CAUTION: Unplug the AC adapter while you make or otherwise work with the connections to the headers. This will protect your BL2600 from inadvertent shorts or power spikes.

2.2.1 Hardware Reset

A hardware reset is done by unplugging the ACV adapter, then plugging it back in, or by pressing the **RESET** button located just above the RabbitCore module.

2.3 Installing Dynamic C

If you have not yet installed Dynamic C version 8.51 (or a later version), do so now by inserting the Dynamic C CD from the BL2600 Tool Kit in your PC's CD-ROM drive. The CD will auto-install unless you have disabled auto-install on your PC.

If the CD does not auto-install, click **Start > Run** from the Windows **Start** button and browse for the Dynamic C **setup.exe** file on your CD drive. Click **OK** to begin the installation once you have selected the **setup.exe** file.

The online documentation is installed along with Dynamic C, and an icon for the documentation menu is placed on the workstation's desktop. Double-click this icon to reach the menu. If the icon is missing, create a new desktop icon that points to **default.htm** in the **docs** folder, found in the Dynamic C installation folder.

The latest versions of all documents are always available for free, unregistered download from our Web sites as well.

The *Dynamic C User's Manual* provides detailed instructions for the installation of Dynamic C and any future upgrades.

NOTE: If you have an earlier version of Dynamic C already installed, the default installation of the later version will be in a different folder, and a separate icon will appear on your desktop.

Once your installation is complete, you will have up to three icons on your PC desktop. One icon is for Dynamic C, one opens the documentation menu, and the third is for the Rabbit Field Utility, a tool used to download precompiled software to a target system.

If you have purchased any of the optional Dynamic C modules, install them after installing Dynamic C. The modules may be installed in any order. You must install the modules in the same directory where Dynamic C was installed.

2.4 Starting Dynamic C

Once the BL2600 is connected to your PC and to a power source, start Dynamic C by double-clicking on the Dynamic C icon on your desktop or in your **Start** menu.

If you are using a USB port to connect your computer to the BL2600, choose **Options > Project Options** and check “Use USB to Serial Converter” in “Serial Options” on the **Communications** tab. Click **OK** to save the settings.

If you are using a BL2600 model running at 44.2 MHz, set the compiler to run the application in the fast program execution SRAM by selecting “Code and BIOS in Flash, Run in RAM” in the “BIOS Memory Setting” on the **Compiler** tab under the **Options > Project Options** menu. Click **OK** to save the settings.

Dynamic C defaults to using the serial port on your PC that you specified during installation. If the port setting is correct, Dynamic C should detect the BL2600 and go through a sequence of steps to cold-boot the BL2600 and to compile the BIOS. (Some versions of Dynamic C will not do the initial BIOS compile and load until the first time you compile a program.)

If you receive the message **No Rabbit Processor Detected**, the programming cable may be connected to the wrong COM port, a connection may be faulty, or the target system may not be powered up. First, check both ends of the programming cable to ensure that it is firmly plugged into the PC and the programming port.

If there are no faults with the hardware, select a different COM port within Dynamic C. On your computer, open **Control Panel > System > Hardware > Device Manager > Ports** and look at the list of available COM ports. In Dynamic C, select **Options > Project Options**, then select one of these available COM ports on the **Communications** tab, then click **OK**. Press **<Ctrl-Y>** to force Dynamic C to recompile the BIOS. If Dynamic C still reports it is unable to locate the target system, repeat the above steps for another available COM port. You should receive a **Bios compiled successfully** message once this step is completed successfully.

If Dynamic C appears to compile the BIOS successfully, but you then receive a communication error message when you compile and load a sample program, it is possible that your PC cannot handle the higher program-loading baud rate. Try changing the maximum download rate to a slower baud rate as follows.

- Locate the **Serial Options** dialog in the Dynamic C **Options > Communications** menu. Select a slower Max download baud rate. Click **OK** to save the settings.

If a program compiles and loads, but then loses target communication before you can begin debugging, it is possible that your PC cannot handle the default debugging baud rate. Try lowering the debugging baud rate as follows.

- Locate the **Serial Options** dialog in the Dynamic C **Options > Communications** menu. Choose a lower debug baud rate. Click **OK** to save the settings.

2.5 PONG.C

You are now ready to test your set-up by running a sample program.

Find the file **PONG.C**, which is in the Dynamic C **SAMPLES** folder. To run the program, open it with the **File** menu (if it is not still open), compile it using the **Compile** menu, and then run it by selecting **Run** in the **Run** menu. The **STDIO** window will open and will display a small square bouncing around in a box.

This program shows that the CPU is working. The sample program described in Section 5.2.3, “Run the PINGME.C Demo,” tests the TCP/IP portion of the board.

2.6 Where Do I Go From Here?

NOTE: If you purchased your BL2600 through a distributor or Rabbit partner, contact the distributor or partner first for technical support.

If there are any problems at this point:

- Use the Dynamic C **Help** menu to get further assistance with Dynamic C.
- Check the Rabbit Technical Bulletin Board and forums at www.rabbit.com/support/bb/ and at www.rabbit.com/forums/.
- Use the Technical Support e-mail form at www.rabbit.com/support/questionSubmit.shtml.

If the sample program ran fine, you are now ready to go on to explore other BL2600 features and develop your own applications.

Chapter 3, “Subsystems,” provides a description of the BL2600’s features, Chapter 4, “Software,” describes the Dynamic C software libraries and introduces some sample programs, and Chapter 5, “Using the TCP/IP Features,” explains the TCP/IP features.

3. SUBSYSTEMS

Chapter 3 describes the principal subsystems for the BL2600.

- Digital I/O
- Serial Communication
- A/D Converter Inputs
- D/A Converter Outputs
- Analog Reference Voltage Circuit
- Memory

Figure 5 shows these Rabbit-based subsystems designed into the BL2600.

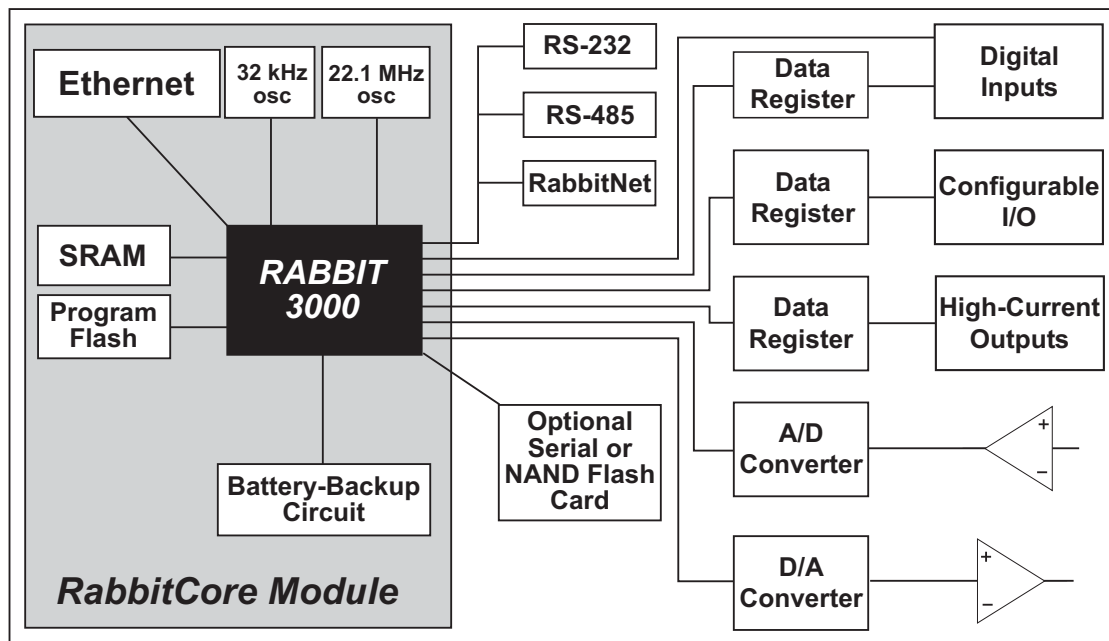

Figure 5. BL2600 Subsystems

3.1 BL2600 Pinouts

The BL2600 pinouts are shown in Figure 6(a) and Figure 6(b).

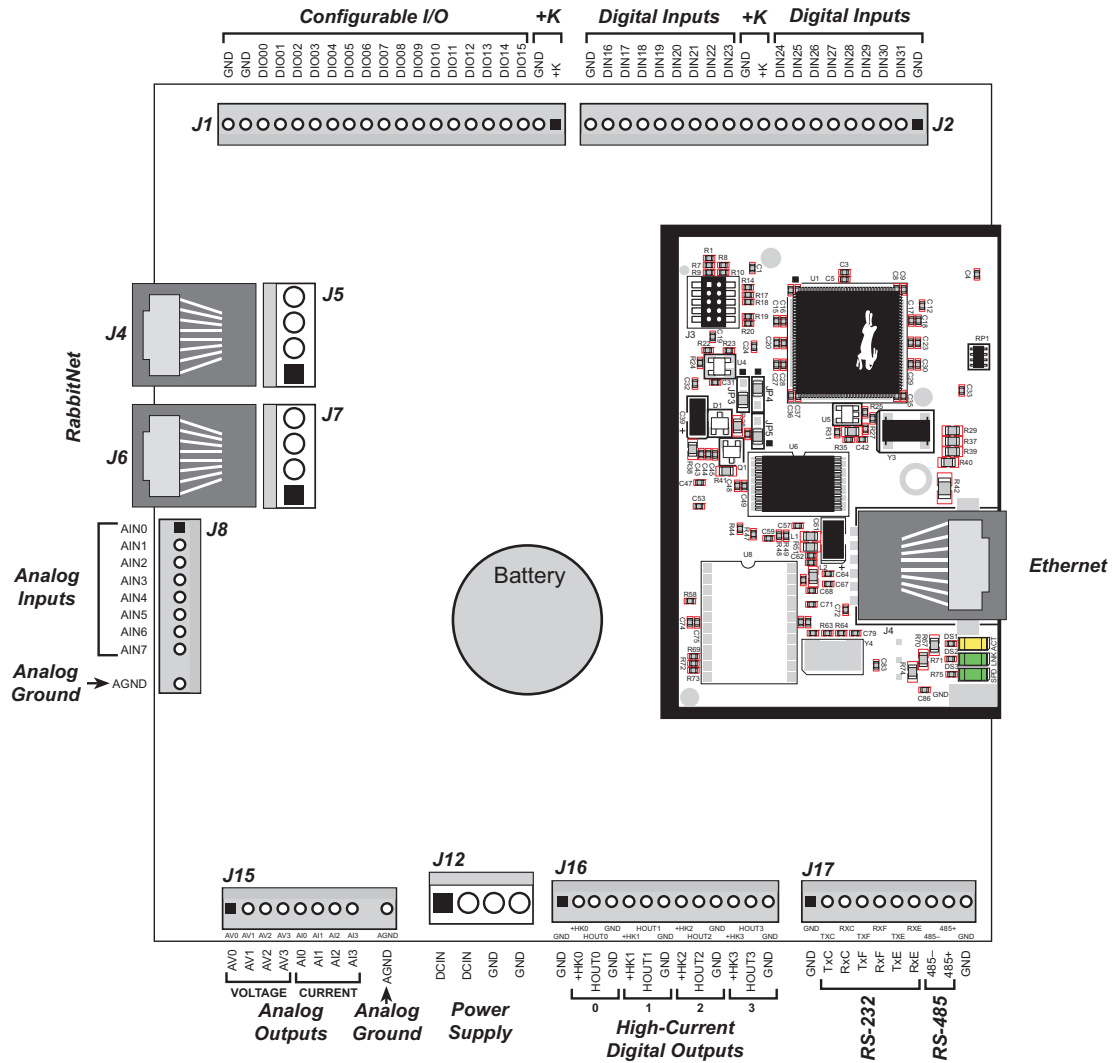

Figure 6(a). BL2600 Pinouts (friction-lock connectors)

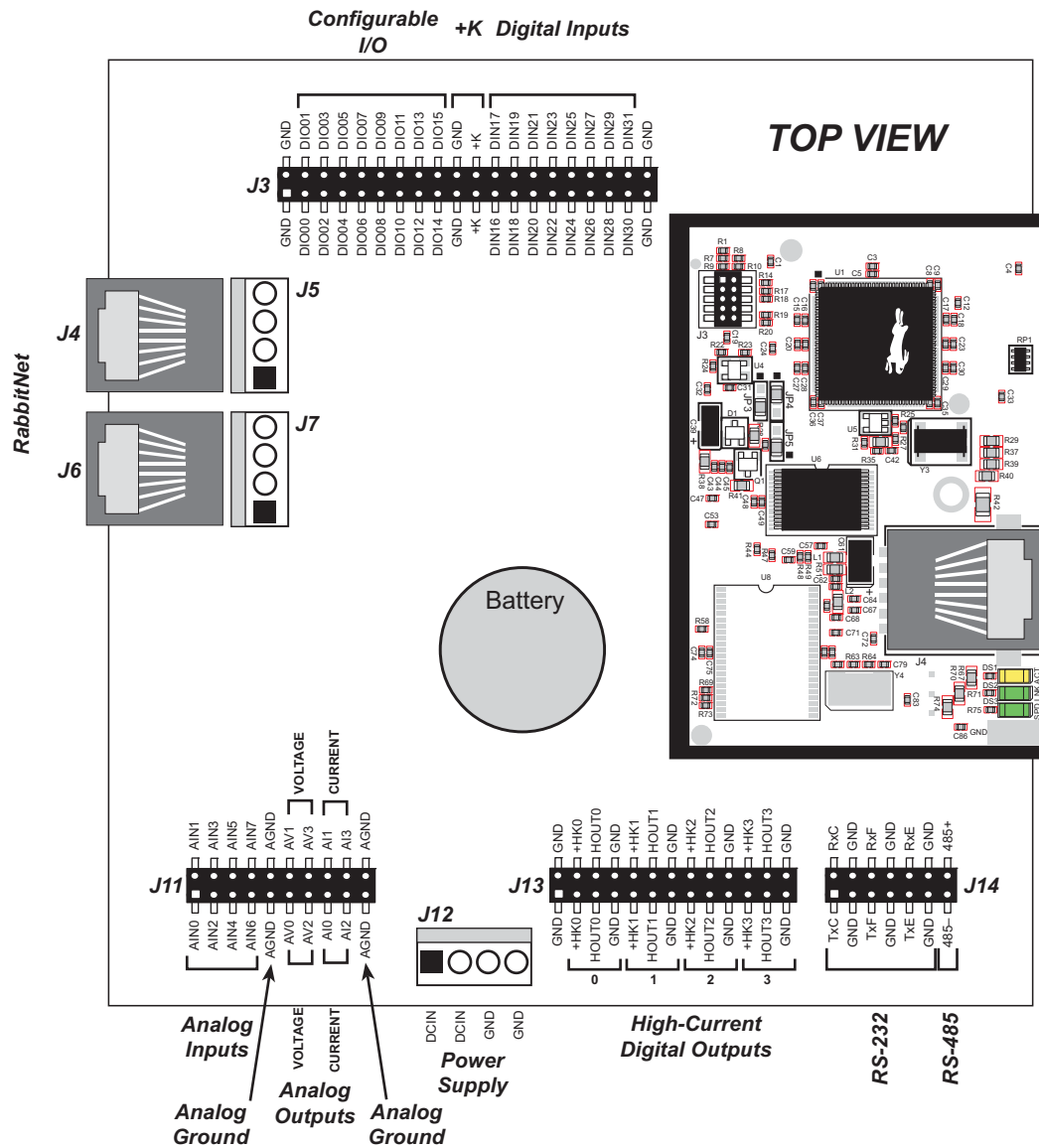

Figure 6(b). BL2600 Pinouts (IDC sockets)

NOTE: Remember that the pinouts will mirror those shown above when they are viewed from the other side of the board.

3.1.1 Connector Options

Standard BL2600 models are equipped with two 1 × 20 friction-lock connector terminals (J1 and J2), two polarized 1 × 10 friction-lock connector terminals (J8 and J15) where pin 9 is removed to polarize the connector terminals, one 1 × 13 friction-lock connector terminal (J16), and one 1 × 10 friction-lock connector terminal (J17); all of these friction-lock connector terminals have a 0.1" pitch.

Two 4-pin 0.156" friction-lock connector terminals at J5 and J7 are installed to supply power (DCIN and +5 V) to the RabbitNet peripheral expansion boards. The 4-pin 0.156" friction-lock connector terminal at J12 is for the main power supply connections.

Table 3 lists Molex connector part numbers for the crimp terminals, housings, and polarizing keys needed to assemble female friction-lock connector assemblies for use with their male counterparts on the BL2600.

Table 3. Female Friction-Lock Connector Parts

Friction-Lock Connector	Used with BL2600 Headers	Molex Housing Part Number	Molex Crimp Terminals	Molex Polarizing Keys
0.1" 1 × 20	J1, J2	22-01-2207	08-50-0113	15-04-9209
0.1" 1 × 13	J16	22-01-2137		
0.1" 1 × 10	J8, J15, J17	22-01-2107		
0.156" 1 × 4	J5, J7, J12	09-50-3041	08-50-0108	15-04-0219

The RJ-45 jacks at J4 and J6 labeled **RabbitNet** are serial I/O expansion ports for use with RabbitNet peripheral expansion boards. The **RabbitNet** jacks do *not* support Ethernet connections. Be careful to make your Ethernet connection to the jack labeled **Ethernet** in the above diagram (note that BL2610 models do not have an Ethernet port).

The BL2600 also has 2 × 20, 2 × 13, 2 × 10, and 2 × 7 IDC sockets with a pitch of 0.1" in addition to the friction-lock connectors. Corresponding headers or ribbon cables may be plugged into these sockets from either the top or the bottom. A top view of the pinouts for these sockets is shown in Figure 6(b).

3.2 Digital I/O

3.2.1 Digital Inputs

The BL2600 has 16 digital inputs, DIN16–DIN31, each of which is protected over a range of –36 V to +36 V. The inputs are factory-configured to be pulled up to +5 V, but they can also be pulled up to +K or DCIN, or pulled down to 0 V in banks by changing a jumper as shown in Figure 7.

 **CAUTION:** Do not simultaneously jumper more than one setting on a particular jumper header (JP3, JP4, and JP5) when configuring a bank of digital inputs.

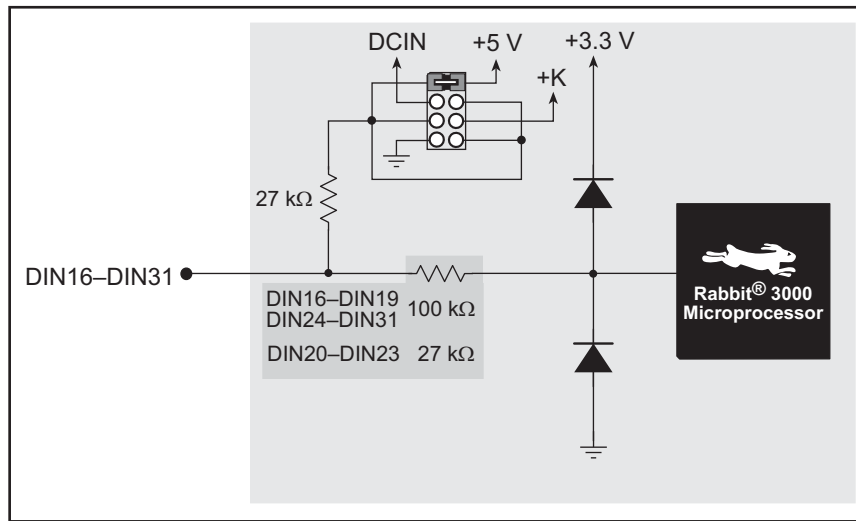

Figure 7. BL2600 Digital Inputs DIN16–DIN31 [Pulled Up—Factory Default]

Table 4 lists the banks of digital inputs and summarizes the jumper settings.

Table 4. Banks of BL2600 Digital Inputs

Digital Inputs	Header	Pins Jumpered	Pulled Up/Pulled Down
DIN16–DIN19	JP3	1–2	Inputs pulled up to +5 V
DIN20–DIN23	JP4	3–4	Inputs pulled up to DCIN
DIN24–DIN31	JP5	5–6	Inputs pulled up to +K
		7–8	Inputs pulled down to GND

When you use the software `digIn` function call to read the digital inputs, DIN16–DIN31 are considered to be digital input channels 16–31.

The actual switching threshold is approximately 1.40 V. Anything below this value is a logic 0, and anything above is a logic 1. The digital inputs are each fully protected over a range of -36 V to +36 V, and can handle short spikes of ± 40 V.

NOTE: If the inputs are pulled up to +K or to DCIN, the voltage range over which the digital inputs are protected changes to +K (or DCIN) - 36 V to +36 V.

Individual DIN16–DIN23 channels may be used for interrupts, input capture, as quadrature decoders, or as PWM outputs.

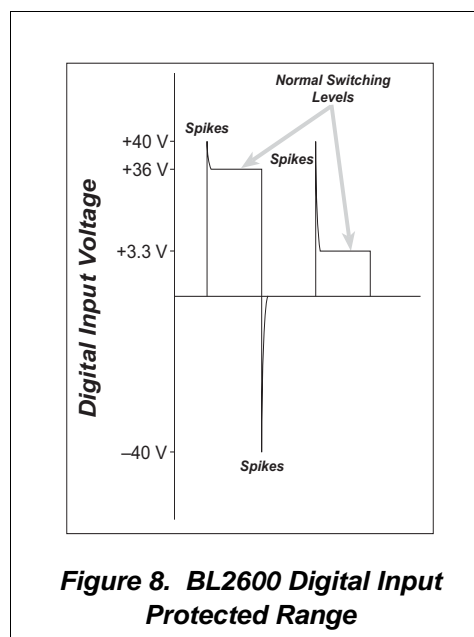

The use of these channels for interrupts, input capture, and as quadrature decoders is described in the *Rabbit 3000 Microprocessor User's Manual*, and is illustrated through sample programs in the Dynamic C `SAMPLES\RABBIT3000` folder. Table 5 lists these alternate uses.

Table 5. Alternate Uses for BL2600 Channels DIN16–DIN23

Channel	Interrupt	Input Capture	Quadrature Decoder	PWM Outputs
DIN16	×			
DIN17	×			
DIN18			×	
DIN19		×	×	
DIN20			×	×
DIN21		×	×	×
DIN22			×	×
DIN23		×	×	×

3.2.2 PWM Outputs

Digital inputs DIN20–DIN23 can be used as PWM output channels by setting the jumper on header JP4 across pins 7–8 to pull the digital inputs to ground. Once the PWM driver sets up a given PWM channel, the corresponding digital input channel is no longer available for use as a digital input. The output voltage swing will be 0 to 1.65 V, which is not suitable for interfacing only to CMOS-level inputs. Since the output impedance is approximately 13 k Ω , the input impedance of the circuit the PWM output is connected to should be at least 10 times as high.

The sample program `PWM.C` in the `IO` subdirectory in `SAMPLES\BL2600` shows how to set up and use the PWM outputs.

3.2.3 High-Current Digital Outputs

The BL2600 has four high-current digital outputs, HOUT0–HOUT3, which can each sink or source up to 2 A. Figure 9 shows a wiring diagram for using the digital outputs in either a sinking or a sourcing configuration.

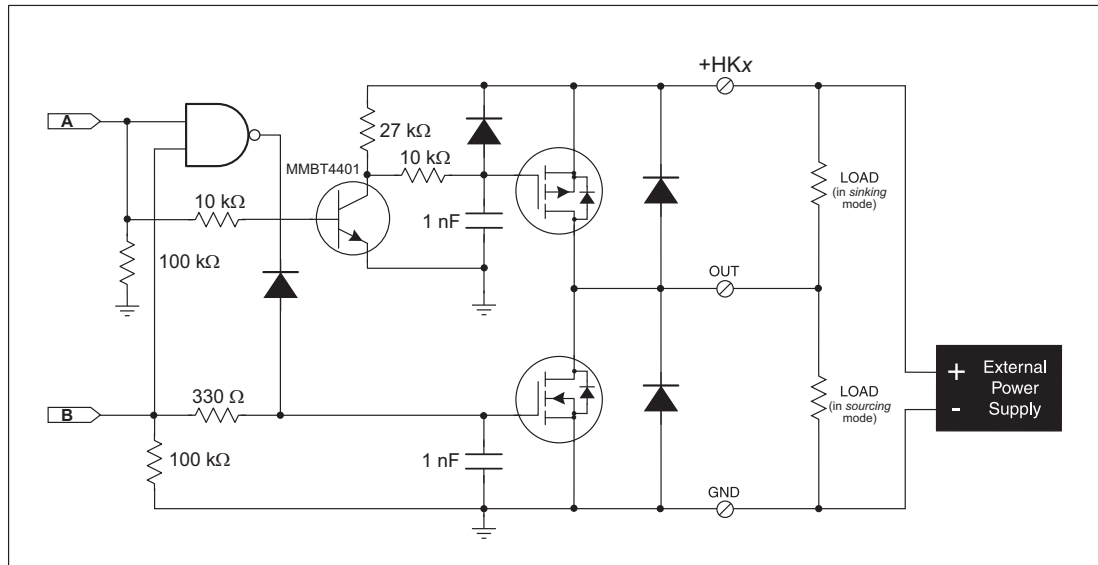



Figure 9. BL2600 High-Current Digital Outputs

All the digital outputs sink and source actively. They can be used as high-side drivers, low-side drivers, or as an H-bridge driver. When the BL2600 is first powered up or reset, all the outputs are disabled, that is, at a high-impedance tristate, until the `digHoutConfig` software function call is made. The `digHoutConfig` call sets the initial state of each high-current output according to the configuration specified by the user, and enables the digital outputs to their initial status.

Table 6. BL2600 High-Current Outputs Logic States

U3 Output		High-Current Output
A	B	
High	High	Prohibited (defaults to sourcing)
High	Low	Sourcing
Low	High	Sinking
Low	Low	High-impedance (tristate)

Each high-current output has its own +K supply. When wiring the high-current outputs, keep the distance to the power supply as short as possible.



CAUTION: If you are using a BL2600 with the IDC header connectors, beware that an individual IDC header pin can only handle up to 1 A. Since the same high-current outputs are available on opposite pairs of IDC header connectors, you can still use the 2 A sinking or sourcing capability of the BL2600 by wiring all your connections, including the ground, in parallel to the opposite pairs (see Figure 10 for an example).

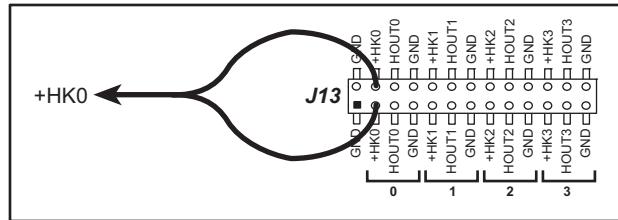

Figure 10. Example of Wiring HK0 In Parallel on IDC Header

For the H bridge, which is shown in Figure 11, *Ka and Kb should be the same.*

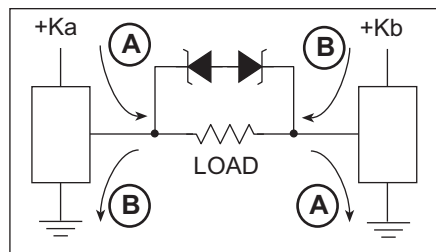

Figure 11. H Bridge

3.2.4 Configurable I/O

The BL2600 has 16 configurable I/O that may be configured individually in software as either digital inputs or as sinking digital outputs. By default, a configurable I/O channel is a digital input, but may be set as a sinking digital output by using the `digOutConfig` function call. The inputs are factory-configured to be pulled up to +5 V, but they can also be pulled up to +K or DCIN, or pulled down to 0 V in banks by changing a jumper as shown in Figure 12.

CAUTION: Do not simultaneously jumper more than one setting on a particular jumper header (JP1 and JP2) when configuring a bank of configurable I/O.

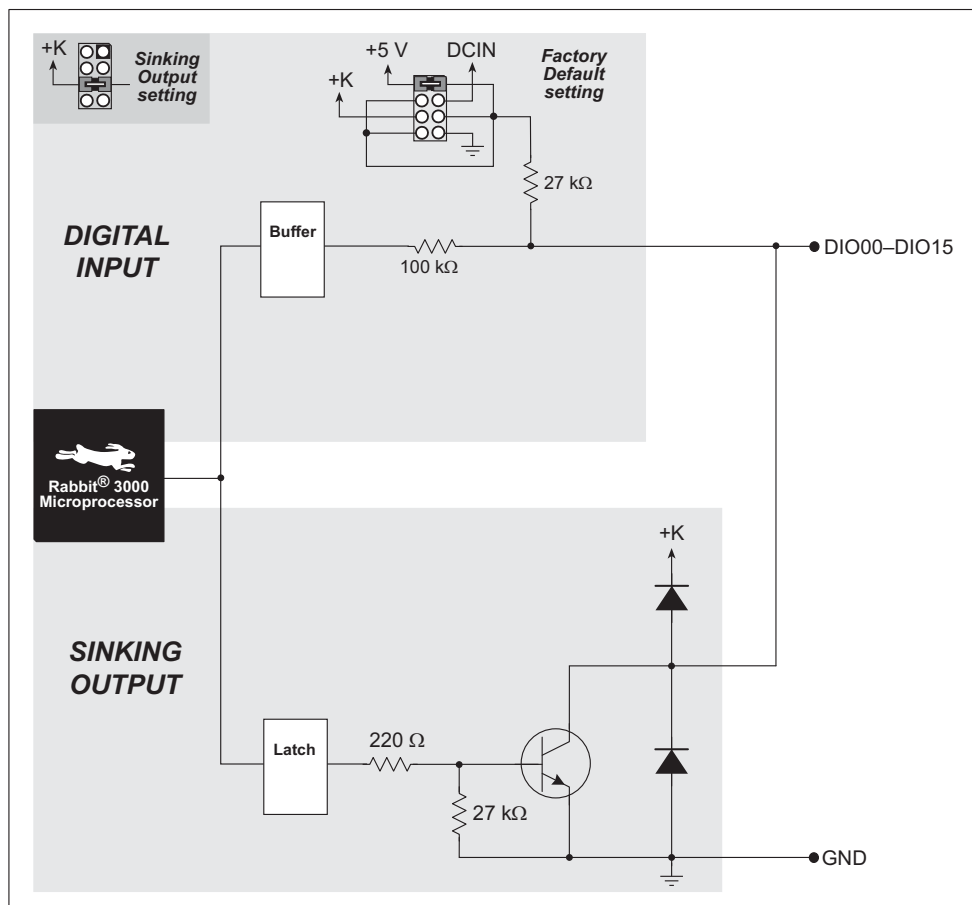

Figure 12. BL2600 Configurable I/O DIO00-DIO15 [Inputs Pulled Up—Factory Default]

When you use the software **digIn** function call to read the configurable I/O, DIO00–DIO15 are considered to be digital input channels 00–15. Note that the **digIn** function call can also read these channels if they are set to be sinking digital outputs.

Table 7 lists the banks of configured digital inputs and summarizes the jumper settings.

Table 7. Banks of BL2600 Configured Digital Inputs

Digital Inputs	Header	Pins Jumpered	Pulled Up/Pulled Down
DIO00–DIO07	JP1	1–2	Inputs pulled up to +5 V
DIO08–DIO15	JP2	3–4	Inputs pulled up to DCIN
		5–6	Inputs pulled up to +K
		7–8	Inputs pulled down to GND

As for the nonconfigurable digital inputs, the actual switching threshold is approximately 1.40 V. Anything below this value is a logic 0, and anything above is a logic 1. The digital inputs are each fully protected over a range of -36 V to +36 V, and can handle short spikes of ± 40 V.

NOTE: If the inputs are pulled up to +K or to DCIN, the voltage range over which the digital inputs are protected changes to +K (or DCIN) – 36 V to +36 V.

When set as a sinking digital output, a configurable I/O channel can sink up to 200 mA at up to 40 V. When you use the software **digOutConfig** function call to set the configurable I/O, DIO00–DIO15 are considered to be digital output channels 00–15. The output can be set up either as a sinking output or it can be put in a high-impedance tristate.

When a configurable I/O is configured as a sinking output, be sure to connect an external voltage source up to 36 V DC across +K and GND on header J1/J3, and set the pullup jumper on the corresponding JP1/JP2 header to +K.

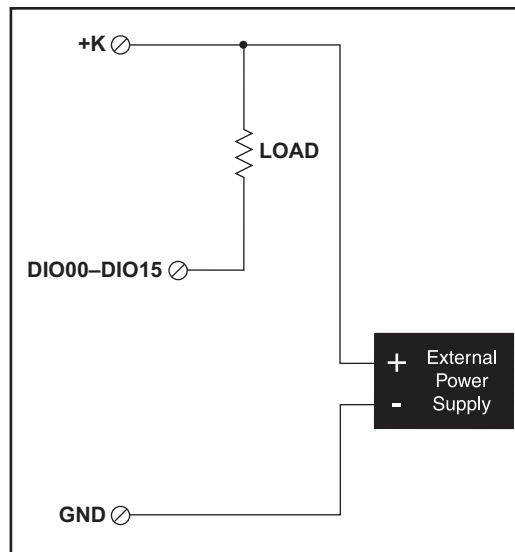

Figure 13. Load and +K Power Supply Connections for Sinking Digital Output

3.3 Serial Communication

The BL2600 has three serial communication ports, which can be configured as one RS-232 serial channel (with RTS/CTS) and one RS-232 (3-wire) channel or one RS-485 channel, or as three RS-232 (3-wire) channels, or as two RS-232 (3-wire) channels and one RS-485 channel by using the `serMode` software function call. Table 8 summarizes the options.

Table 8. Serial Communication Configurations

Mode	Serial Port		
	C	E	F
0	RS-232, 3-wire	RS-232, 3-wire	RS-232, 3-wire
1	RS-232, 3-wire	RS-485	RS-232, 3-wire
2	RS-232, 5-wire	RS-232, 3-wire	CTS/RTS
3	RS-232, 5-wire	RS-485	CTS/RTS

The BL2600 also has one CMOS serial channel that serves as the programming port.

All four serial ports operate in an asynchronous mode. An asynchronous port can handle 7 or 8 data bits. A 9th bit address scheme, where an additional bit is sent to mark the first byte of a message, is also supported. Serial Port A, the programming port, can be operated alternately in the clocked serial mode. In this mode, a clock line synchronously clocks the data in or out. Either of the two communicating devices can supply the clock. The BL2600 boards typically use all four ports in the asynchronous serial mode. Serial Ports C and F are used for RS-232 communication, and Serial Port E is used for RS-232 or RS-485 communication. The BL2600 uses a 22.12 MHz resonator, which is doubled to 44.2 MHz. At this frequency, the BL2600 supports standard asynchronous baud rates up to a maximum of 5.525 Mbps.

3.3.1 RS-232

The BL2600 RS-232 serial communication is supported by an RS-232 transceiver. This transceiver provides the voltage output, slew rate, and input voltage immunity required to meet the RS-232 serial communication protocol. Basically, the chip translates the Rabbit 3000's CMOS signals to RS-232 signal levels. Note that the polarity is reversed in an RS-232 circuit so that a +3.3 V output becomes approximately -10 V and 0 V is output as +10 V. The RS-232 transceiver also provides the proper line loading for reliable communication.

RS-232 can be used effectively at the BL2600's maximum baud rate for distances of up to 15 m.

3.3.2 RS-485

The BL2600 can be set for one RS-485 serial channel, which is connected to the Rabbit 3000 Serial Port E through an RS-485 transceiver. The half-duplex communication uses the Rabbit 3000's PE3 pin to control the transmit enable on the communication line.

The BL2600 can be used in an RS-485 multidrop network. Connect the 485+ to 485+ and 485- to 485- using single twisted-pair wires (nonstranded, tinned) as shown in Figure 14. Note that a common ground is recommended.

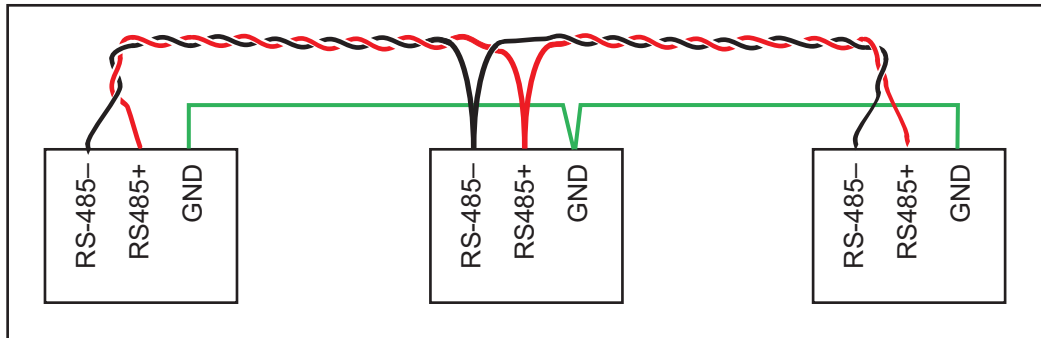

Figure 14. BL2600 Multidrop Network

The BL2600 comes with a 220 Ω termination resistor and two 681 Ω bias resistors installed and enabled with jumpers across pins 1–2 and 5–6 on header JP7, as shown in Figure 15.

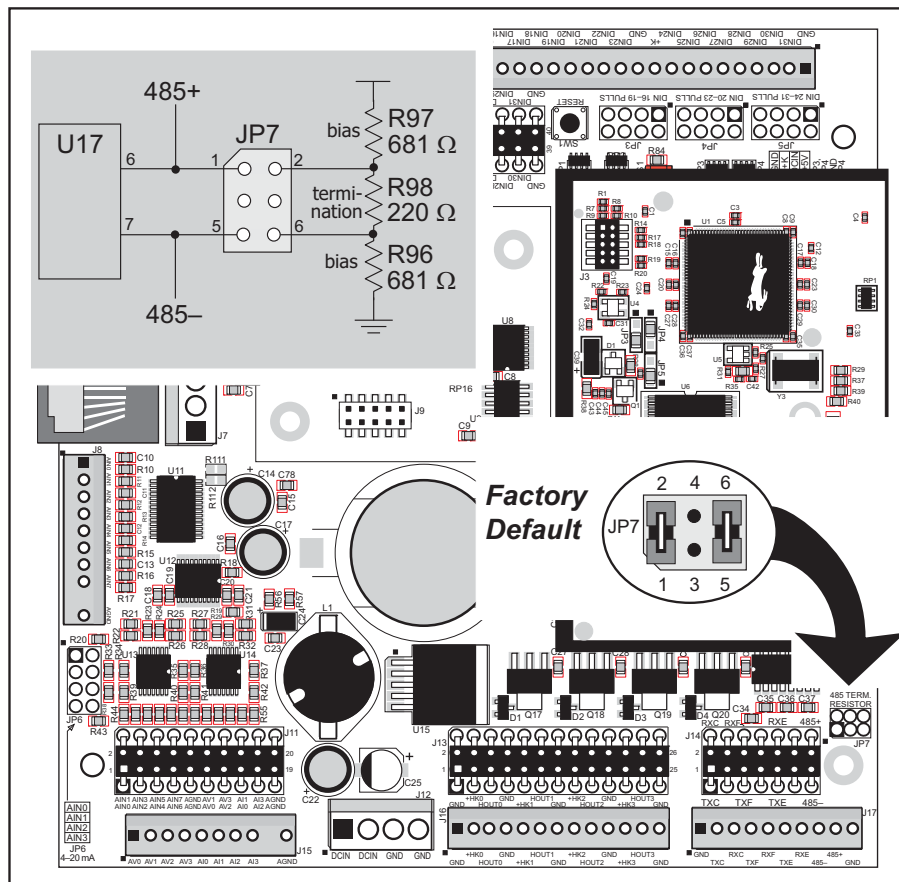

Figure 15. RS-485 Termination and Bias Resistors

For best performance, the bias and termination resistors in a multidrop network should only be enabled on both end nodes of the network. Disable the termination and bias resistors on any intervening BL2600 units in the network by removing both jumpers from header JP6.

TIP: Save the jumpers for possible future use by “parking” them across pins 1–3 and 4–6 of header JP7. Pins 3 and 4 are not otherwise connected to the BL2600.

3.3.3 Programming Port

The RabbitCore module on the BL2600 has a 10-pin programming header. The programming port uses the Rabbit 3000’s Serial Port A for communication, and is used for the following operations.

- Programming/debugging
- Cloning

The programming port is used to start the BL2600 in a mode where the BL2600 will download a program from the port and then execute the program. The programming port transmits information to and from a PC while a program is being debugged.

The Rabbit 3000 startup-mode pins (SMODE0, SMODE1) are presented to the programming port so that an externally connected device can force the BL2600 to start up in an external bootstrap mode. The BL2600 can be reset from the programming port via the **/EXT_RSTIN** line.

The Rabbit 3000 status pin is also presented to the programming port. The status pin is an output that can be used to send a general digital signal.

NOTE: Refer to the *Rabbit 3000 Microprocessor User’s Manual* for more information related to the bootstrap mode.

3.3.4 Ethernet Port

Figure 16 shows the pinout for the Ethernet port (J4 on the BL2600 module). Note that there are two standards for numbering the pins on this connector—the convention used here, and numbering in reverse to that shown. Regardless of the numbering convention followed, the pin positions relative to the spring tab position (located at the bottom of the RJ-45 jack in Figure 16) are always absolute, and the RJ-45 connector will work properly with off-the-shelf Ethernet cables.

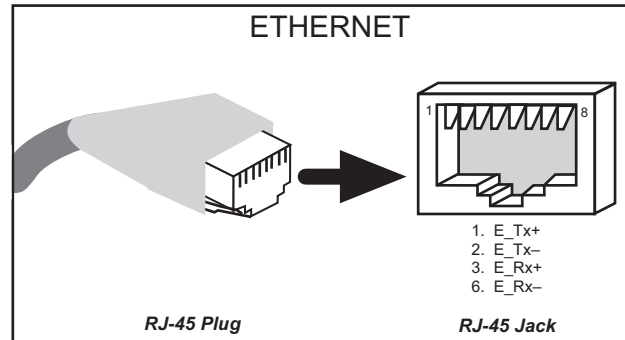

Figure 16. RJ-45 Ethernet Port Pinout

Two LEDs are placed next to the RJ-45 Ethernet jack, one to indicate an Ethernet link (**LNK**) and one to indicate Ethernet activity (**ACT**).

The RJ-45 connector is shielded to minimize EMI effects to/from the Ethernet signals.

3.4 A/D Converter Inputs

The single A/D converter chip used in the BL2600 has a resolution of 12 bits (11 bits for the value and one bit for the polarity). The A/D converter chip has a programmable amplifier. Each external input has circuitry that provides scaling and filtering. All 8 external inputs are scaled and filtered to provide the user with an input impedance of 1 M Ω and a variety of single-ended unipolar, single-ended bipolar, and differential bipolar ranges as shown in Table 9.

Figure 17 shows a pair of A/D converter input circuits. The resistors form an approx. 10:1 attenuator, and the capacitors filter noise pulses from the A/D converter inputs.

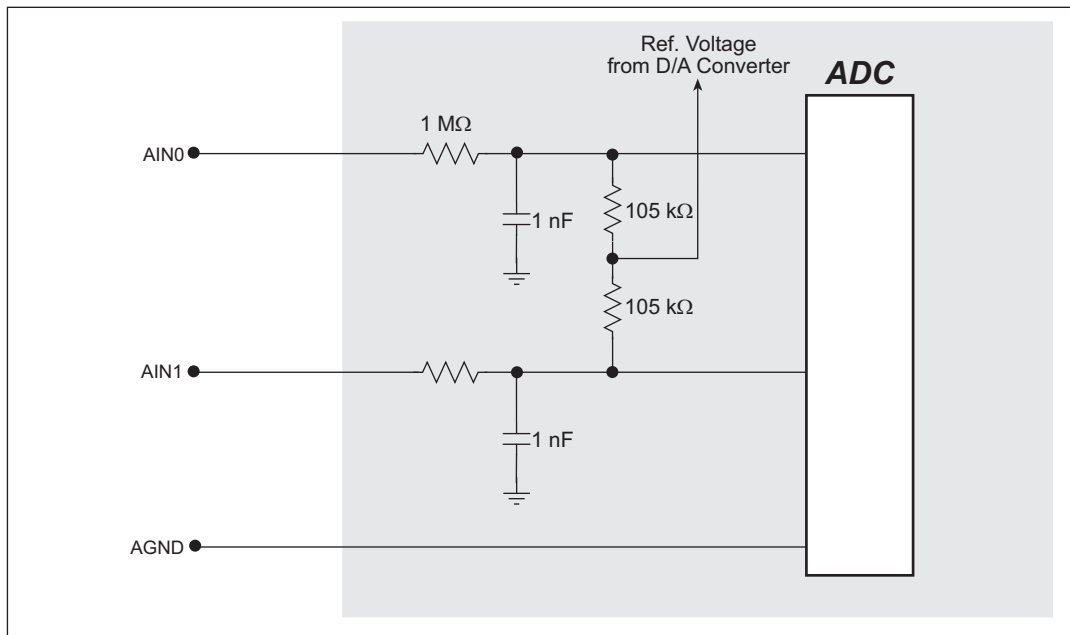

Figure 17. Buffered A/D Converter Inputs

The A/D converter chip can only accept positive voltages. By pairing the analog inputs and setting the reference voltage from the D/A converter [0 V for single-ended unipolar or differential measurements, $V = (\text{voltage range}) \div 9$ for single-ended bipolar measurements], single-ended unipolar, single-ended bipolar, differential bipolar, or current (4–20 mA on channels 0–3 only) measurements are possible, and can be configured for each channel or channel pair with the `opmode` parameter in the `anaInConfig` software function call. Adjacent A/D converter inputs are paired to make bipolar measurements. The default setup is to measure only voltages for the ranges listed in Table 9.

Table 9. A/D Converter Input Voltage Ranges

Amplifier Gain	Voltage Range			mV per Tick
	Single-Ended Unipolar	Single-Ended Bipolar	Differential Bipolar	
1	0–20 V	±10 V	± 20 V	10
2	0–10 V	±5 V	± 10 V	5
4	0–5 V	±2.5 V	± 5 V	2.5
5	0–4 V	±2 V	± 4 V	2.0
8*	0–2.5 V	±1.25 V	± 2.5 V	1.25
10	0–2 V	±1 V	± 2 V	1.0
16	0–1.25 V	±0.625 V	± 1.25 V	0.625
20	0–1 V	±0.5 V	± 1 V	0.500

* 4–20 mA operation is available with an amplifier gain of 8

When using channels AIN0–AIN3 for current measurements, remember to set the corresponding jumper(s) on header JP6.

The A/D converter inputs are factory-calibrated and the calibration constants are stored in a separate EEPROM.

3.4.1 A/D Converter Calibration

To get the best results from the A/D converter, it is necessary to calibrate each mode (single-ended, differential, and current) for each of its gains. It is imperative that you calibrate each of the A/D converter inputs in the same manner as they are to be used in the application. For example, if you will be performing floating differential measurements or differential measurements using a common analog ground, then calibrate the A/D converter in the corresponding manner. The calibration table in software only holds calibration constants based on mode, channel, and gain. *Other factors affecting the calibration must be taken into account by calibrating using the same mode and gain setup as in the intended use.*

Sample programs are provided to illustrate how to read and calibrate the various A/D inputs for the three operating modes.

Mode	Read	Calibrate
Single-Ended, unipolar	AD_RD_SE_UNIPOLAR.C	ADC_CAL_SE_UNIPOLAR.C
Single-Ended, bipolar	AD_RD_SE_BIPOLAR.C	ADC_CAL_SE_BIPOLAR.C
Differential, bipolar	AD_RD_DIFF.C	ADC_CAL_DIFF.C
Milli-Amp	AD_RD_MA.C	ADC_CAL_MA.C

These sample programs are found in the **ADC** subdirectory in **SAMPLES\BL2600**. See Section 4.2.4 for more information on these sample programs and how to use them.

3.5 D/A Converter Outputs

The four D/A converter outputs are buffered and scaled to provide an output from 0 V to +10 V (12-bit resolution) or ± 10 V (11-bit resolution, one bit used for polarity). There are also four 4–20 mA current outputs. Figure 18 shows the D/A converter outputs.

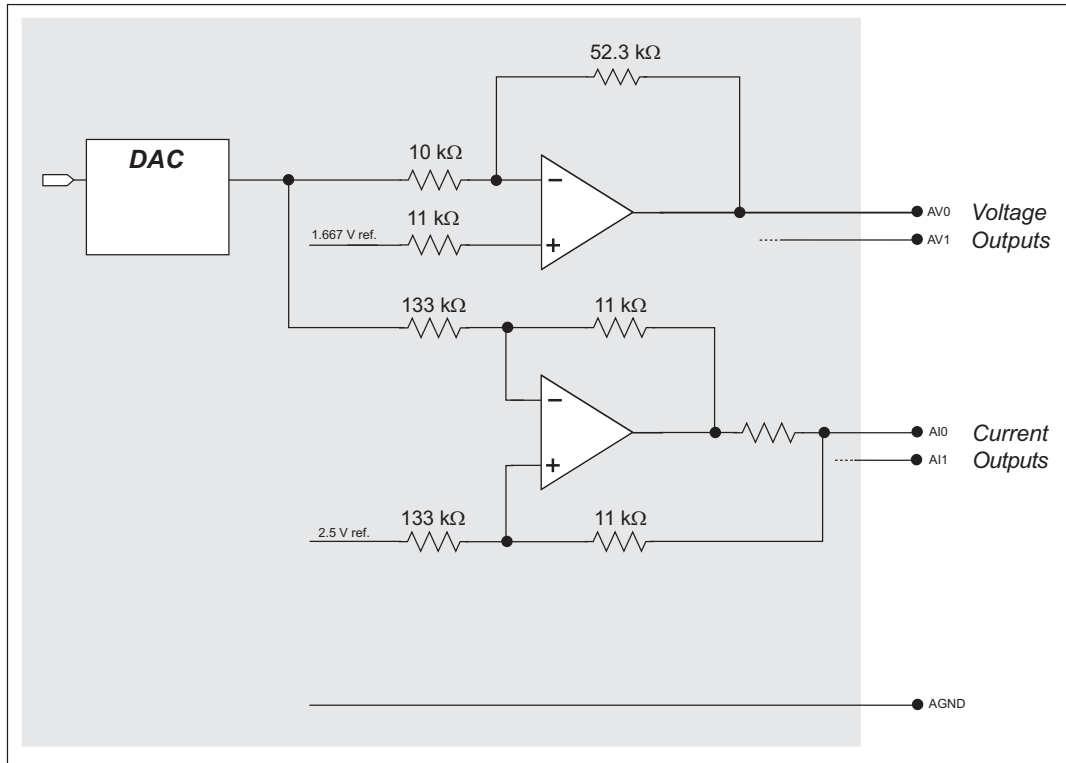

Figure 18. D/A Converter Outputs

To stay within the maximum power dissipation of the D/A converter circuit, the maximum D/A converter output current is 10 mA per channel for the voltage outputs. If you are using the current outputs, keep the resistance driven by a current output channel below 400 Ω to stay within the voltage compliance capability of the op-amp output circuit.

As Figure 18 shows, both the voltage and the current outputs for a particular channel are driven by the same output on the D/A converter chip. As a result, either the `anaOutVolts` or the `anaOutmAmps` function calls will set both the voltage and the current outputs corresponding to a particular channel. For example, if `anaOutVolts` sets unipolar channel AV0 to be +10 V, AIO will be 20 mA; if `anaOutVolts` sets unipolar channel AV0 to be +5 V, AIO will be 12 mA, the midpoint of the 4–20 mA range. It is possible to connect a load to both the corresponding voltage and current outputs as long as the combined current consumption does not exceed the 20 mA individual limit.

Because of the “connection” between the analog voltage outputs and the analog current outputs, the configuration of the analog voltage outputs with the `anaOutConfig` function call as unipolar outputs with 12-bit resolution or as bipolar outputs with 11-bit resolution

also affects the resolution of the 4–20 mA current outputs—you need to configure a voltage output for unipolar operation if you want 12-bit resolution on the associated current output.

There are other effects on a current output when the associated voltage output is operating in the bipolar mode. While voltages of 0 to +10 V still correspond to currents of 4 to 20 mA, the current cannot be determined reliably for voltages below 0 V, and will be “negative” at voltages below -2.5 V. Thus the current output effectively becomes a “current sink” instead of a “current source.”

The D/A converter outputs are factory-calibrated and the calibration constants are stored in a separate EEPROM.

3.5.1 D/A Converter Calibration

To get the best results from the D/A converter, it is necessary to calibrate each mode (unipolar, bipolar, and current) for each of its gains. It is imperative that you calibrate each of the D/A converter outputs in the same manner as they are to be used in the application. The calibration table in software only holds calibration constants based on unipolar, bipolar, and voltage or current operation. *Other factors affecting the calibration must be taken into account by calibrating using the same mode and voltage/current setup as in the intended use.*

Sample programs are provided to illustrate how to calibrate the various D/A outputs for the three operating modes.

Mode	Calibrate
Voltage	DAC_CAL_VOLTS.C
Current	DAC_CAL_MA.C

These sample programs are found in the **DAC** subdirectory in **SAMPLES\BL2600**. See Section 4.2.5 for more information on these sample programs and how to use them.

3.6 Analog Reference Voltage Circuit

Figure 19 shows the analog voltage reference circuit.

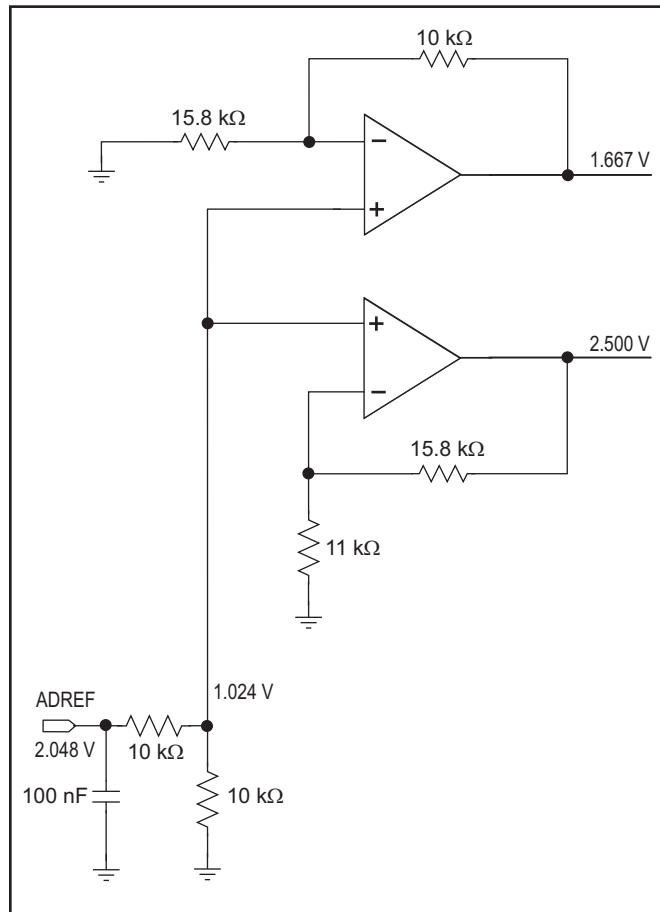

Figure 19. Analog Reference Voltages

The A/D converter chip supplies the 2.048 V reference voltage, which is divided in half and then amplified and buffered to provide the 1.667 V and 2.5 V reference voltages used by the digital output circuits.

The D/A converter chip provides the reference voltages for the digital inputs to provide single-ended unipolar or differential measurements [0 V], or to provide single-ended bipolar measurements [$V = (\text{voltage range}) \div 9$]. Because the D/A converter chip operation is configured by the **anaOutConfig** function, it is important to run the **anaOutConfig** function before running **anaInConfig** if you plan to use the digital outputs to ensure that the reference voltages are established first before the analog inputs are configured.

3.7 Serial Programming Cable

The programming cable is used to connect the serial programming port of the BL2600 to a PC serial COM port. The programming cable converts the RS-232 voltage levels used by the PC serial port to the CMOS voltage levels used by the Rabbit 3000.

When the **PROG** connector on the programming cable is connected to the programming header on the BL2600's RabbitCore module, programs can be downloaded and debugged over the serial interface.

The **DIAG** connector of the programming cable may be used on the programming header on the BL2600's RabbitCore module with the BL2600 operating in the Run Mode. This allows the programming port to be used as a regular serial port.

3.7.1 Changing Between Program Mode and Run Mode

The BL2600 is automatically in Program Mode when the **PROG** connector on the programming cable is attached, and is automatically in Run Mode when no programming cable is attached. When the Rabbit 3000 is reset, the operating mode is determined by the status of the SMODE pins. When the programming cable's **PROG** connector is attached, the SMODE pins are pulled high, placing the Rabbit 3000 in the Program Mode. When the programming cable's **PROG** connector is not attached, the SMODE pins are pulled low, causing the Rabbit 3000 to operate in the Run Mode.

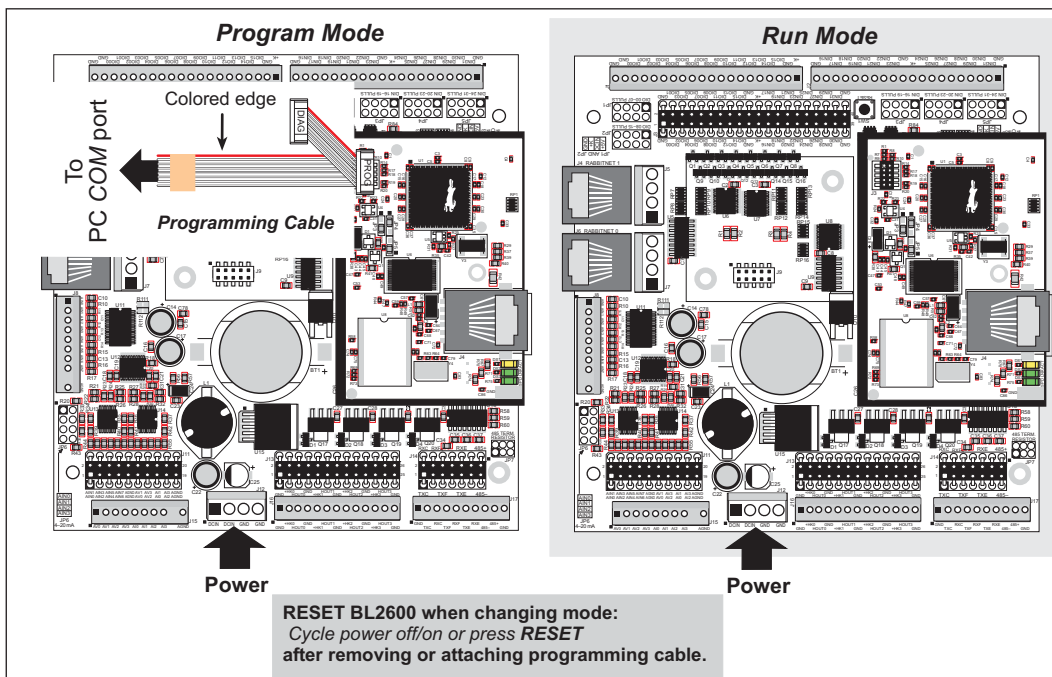

Figure 20. BL2600 Program Mode and Run Mode Setup

A program “runs” in either mode, but can only be downloaded and debugged when the BL2600 is in the Program Mode.

Refer to the *Rabbit 3000 Microprocessor User's Manual* for more information on the programming port and the programming cable.

3.8 Other Hardware

3.8.1 Clock Doubler

The BL2600 takes advantage of the Rabbit 3000 microprocessor's internal clock doubler. A built-in clock doubler allows half-frequency crystals to be used to reduce radiated emissions. The 44.2 MHz frequency specified for the BL2600 is generated using a 22.12 MHz resonator, and the 29.4 MHz frequency specified for the BL2610 is generated using a 14.7456 MHz crystal.

The clock doubler may be disabled if the higher clock speeds are not required. Disabling the Rabbit 3000 microprocessor's internal clock doubler will reduce power consumption and further reduce radiated emissions. The clock doubler is disabled with a simple configuration macro as shown below.

1. Select the "Defines" tab from the Dynamic C **Options > Project Options** menu.
2. Add the line `CLOCK_DOUBLED=0` to always disable the clock doubler.

The clock doubler is enabled by default, and usually no entry is needed. If you need to specify that the clock doubler is always enabled, add the line `CLOCK_DOUBLED=1` to always enable the clock doubler.

3. Click **OK** to save the macro. The clock doubler will now remain off whenever you are in the project file where you defined the macro.

3.8.2 Spectrum Spreader

The Rabbit 3000 features a spectrum spreader, which helps to mitigate EMI problems. By default, the spectrum spreader is on automatically, but it may also be turned off or set to a stronger setting. The means for doing so is through a simple configuration macro as shown below.

1. Select the "Defines" tab from the Dynamic C **Options > Project Options** menu.
2. Normal spreading is the default, and usually no entry is needed. If you need to specify normal spreading, add the line

```
ENABLE_SPREADER=1
```

For strong spreading, add the line

```
ENABLE_SPREADER=2
```

To disable the spectrum spreader, add the line

```
ENABLE_SPREADER=0
```

NOTE: The strong spectrum-spreading setting is not recommended since it may limit the maximum clock speed or the maximum baud rate. It is unlikely that the strong setting will be used in a real application.

3. Click **OK** to save the macro. The spectrum spreader will now remain off whenever you are in the project file where you defined the macro.

NOTE: Refer to the *Rabbit 3000 Microprocessor User's Manual* for more information on the spectrum-spreading setting and the maximum clock speed.

3.9 Memory

3.9.1 SRAM

The BL2600 modules running at clock speeds of 44.2 MHz have 512K of program-execution SRAM. All the BL2600 modules have 256K–512K of data SRAM.

3.9.2 Flash Memory

The BL2600 also has 512K of flash memory.

NOTE: Rabbit recommends that any customer applications should not be constrained by the sector size of the flash memory since it may be necessary to change the sector size in the future.

Writing to arbitrary flash memory addresses at run time is also discouraged. Instead, define a “user block” area to store persistent data. The functions `writeUserBlock` and `readUserBlock` are provided for this.

A Flash Memory Bank Select jumper configuration option based on $0\ \Omega$ surface-mounted resistors exists at location JP4 on the RabbitCore module (BL2600) or at location JP1 on the RabbitCore module (BL2610). These options are reserved for future use.

3.9.3 Serial Flash

Socket J9 is provided to allow you to plug in an optional Rabbit SF1000 serial flash via Serial Port D. You may use two 0.375" (9.5 mm) spacers with 4-40 \times 3/4 screws and nuts to attach the SF1000 securely.

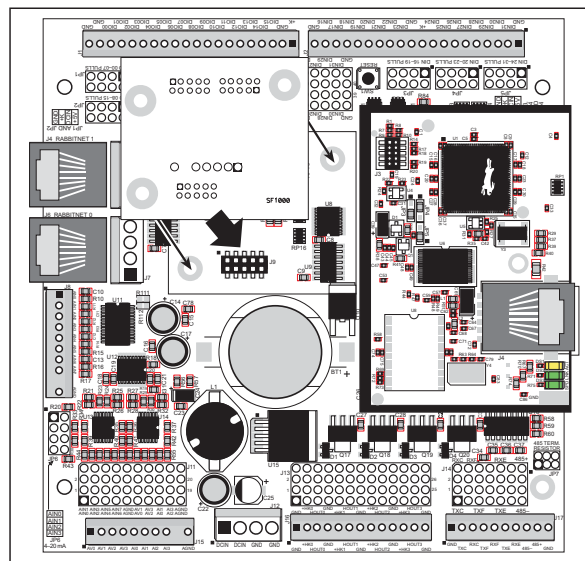

Figure 21. Installation of Optional SF1000 Serial Flash

3.9.4 NAND Flash

The RCM3365 and the RCM3375 RabbitCore modules used with the additional BL2600 versions described in Section 1.2.2 support a removable memory card to store data and Web pages. The RCM3365 and the RCM3375 both can handle up to a 128 MByte removable memory card, and the RCM3365 also has a 16 MByte onboard NAND flash.

NOTE: Rabbit-based systems do not implement the *xD-Picture Card™* specification for data storage, and are neither compatible nor compliant with *xD-Picture Card™* card readers.

The NAND flash and removable memory cards are particularly suitable for mass-storage applications, but are generally unsuitable for direct program execution. The NAND flash differs from parallel NOR flash (the type of flash memory used to store program code on Rabbit-based boards and RabbitCore modules currently in production) in two respects. First, the NAND flash requires error-correcting code (ECC) for reliability. Although NAND flash manufacturers do guarantee that block 0 will be error-free, most manufacturers guarantee that a new NAND flash chip will be shipped with a relatively small percentage of errors, and will not develop more than some maximum number or percentage of errors over its rated lifetime of up to 100,000 writes. Second, the standard NAND flash addressing method multiplexes commands, data, and addresses on the same I/O pins, while requiring that certain control lines must be held stable for the duration of the NAND flash access. The software function calls provided by Rabbit for the NAND flash take care of the data-integrity and reliability attributes.

Figure 22 shows how to insert or remove the memory card. While you remove or insert the memory card, take care to avoid touching the electrical contacts on the bottom of the card to prevent electrostatic discharge damage to the card and to keep any moisture and contaminants off the contacts. Do *not* remove or insert the memory card while it is being accessed.

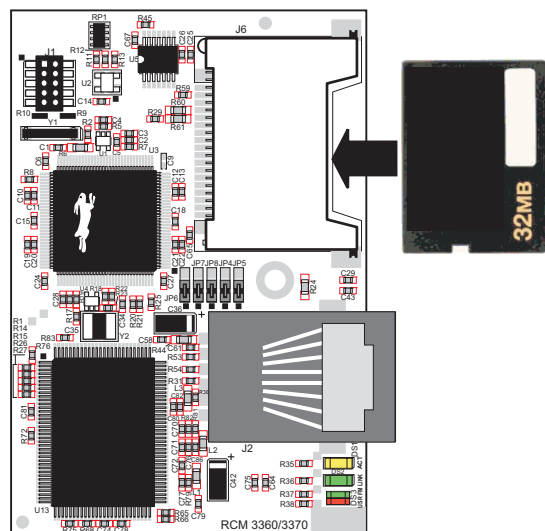

Figure 22. Insertion/Removal of Memory Card

Rabbit recommends that you use header J6 on the RCM3365/RCM3375 only for the memory card since other devices are not supported. Be careful to remove and insert the memory card as shown, and be careful *not* to insert any foreign objects, which may short out the contacts and lead to the destruction of your memory card.

Sample programs in the **SAMPLES\BL2600\NANDFlash** folder illustrate the use of the NAND flash. These sample programs are described in Section 4.2.7, “Use of NAND Flash.” Pay careful attention to the sample programs to see how to close files and secure any data on the memory card before you remove it.

4. SOFTWARE

Dynamic C is an integrated development system for writing embedded software. It runs on an IBM-compatible PC and is designed for use with single-board computers and other devices based on the Rabbit microprocessor.

Chapter 4 provides the libraries, function calls, and sample programs related to the BL2600.

4.1 Running Dynamic C

You have a choice of doing your software development in the flash memory or in the static RAM included on the BL2600. The flash memory and SRAM options are selected with the **Options > Project Options > Compiler** menu.

The advantage of working in RAM is to save wear on the flash memory, which is limited to about 100,000 write cycles. The disadvantage is that the code and data might not both fit in RAM.

NOTE: On the BL2600, compiling a program to flash will produce a warning message. You will receive an error message if you attempt to compile a program to the battery-backed data SRAM. If you still want to compile to the battery-backed data SRAM, you will have to comment out some code as instructed in the error message. The program should be run from the program execution SRAM after the programming cable is disconnected. Your final code must always be stored in flash memory for reliable operation. Select **Code and BIOS in Flash, Run in RAM** from the Dynamic C **Options > Project Options > Compiler** menu to store the code in flash and copy it to the fast program execution SRAM at run-time to take advantage of the faster clock speed. This option optimizes the performance of the BL2600 with an RCM3200 RabbitCore module running at 44.2 MHz.

NOTE: On the BL2610, an application can be developed in RAM, but cannot run standalone from RAM after the programming cable is disconnected. Standalone applications can only run from flash memory.

NOTE: Do not depend on the flash memory sector size or type. Due to the volatility of the flash memory market, the BL2600 and Dynamic C were designed to accommodate flash devices with various sector sizes.

Developing software with Dynamic C is simple. Users can write, compile, and test C and assembly code without leaving the Dynamic C development environment. Debugging occurs while the application runs on the target. Alternatively, users can compile a program to an image file for later loading. Dynamic C runs on PCs under Windows 95, 98, 2000, NT, Me, and XP. Programs can be downloaded at baud rates of up to 460,800 bps after the program compiles.

Dynamic C has a number of standard features:

- Full-feature source and/or assembly-level debugger, no in-circuit emulator required.
- Royalty-free TCP/IP stack with source code and most common protocols.
- Hundreds of functions in source-code libraries and sample programs:
 - ▶ Exceptionally fast support for floating-point arithmetic and transcendental functions.
 - ▶ RS-232 and RS-485 serial communication.
 - ▶ Analog and digital I/O drivers.
 - ▶ I²C, SPI, GPS, file system.
 - ▶ LCD display and keypad drivers.
- Powerful language extensions for cooperative or preemptive multitasking
- Loader utility program to load binary images into Rabbit targets in the absence of Dynamic C.
- Provision for customers to create their own source code libraries and augment on-line help by creating “function description” block comments using a special format for library functions.
- Standard debugging features:
 - ▶ Breakpoints—Set breakpoints that can disable interrupts.
 - ▶ Single-stepping—Step into or over functions at a source or machine code level, μ C/OS-II aware.
 - ▶ Code disassembly—The disassembly window displays addresses, opcodes, mnemonics, and machine cycle times. Switch between debugging at machine-code level and source-code level by simply opening or closing the disassembly window.
 - ▶ Watch expressions—Watch expressions are compiled when defined, so complex expressions including function calls may be placed into watch expressions. Watch expressions can be updated with or without stopping program execution.
 - ▶ Register window—All processor registers and flags are displayed. The contents of general registers may be modified in the window by the user.
 - ▶ Stack window—shows the contents of the top of the stack.
 - ▶ Hex memory dump—displays the contents of memory at any address.
 - ▶ **STDIO** window—`printf` outputs to this window and keyboard input on the host PC can be detected for debugging purposes. `printf` output may also be sent to a serial port or file.

4.1.1 Upgrading Dynamic C

4.1.1.1 Patches and Updates

Dynamic C patches that focus on bug fixes and updates are available from time to time. Check the Web site at www.rabbit.com/support/ for the latest patches, workarounds, and updates.

The default installation of a patch or update is to install the file in a directory (folder) different from that of the original Dynamic C installation. Rabbit recommends using a different directory so that you can verify the operation of the patch or update without overwriting the existing Dynamic C installation. If you have made any changes to the BIOS or to libraries, or if you have programs in the old directory (folder), make these same changes to the BIOS or libraries in the new directory containing the patch. Do *not* simply copy over an entire file since you may overwrite an update; of course, you may copy over any programs you have written. Once you are sure the new patch or update works entirely to your satisfaction, you may retire the existing installation, but keep it available to handle legacy applications.

4.1.1.2 Upgrades

Dynamic C installations are designed for use with the board they are included with, and are included at no charge as part of our low-cost kits. Dynamic C is a complete software development system, but does not include all the Dynamic C features. Rabbit also offers for sale add-on Dynamic C modules containing the popular μ C/OS-II real-time operating system, as well as PPP, Advanced Encryption Standard (AES), RabbitWeb, FAT File System, Secure Socket Layer (SSL) and other select libraries. In addition to the Web-based technical support included at no extra charge, a one-year telephone-based technical support module is also available for purchase.

4.2 Sample Programs

Sample programs are provided in the Dynamic C **Samples** folder. The sample program **PONG.C** demonstrates the output to the **STDIO** window.

The various directories in the **Samples** folder contain specific sample programs that illustrate the use of the corresponding Dynamic C libraries.

The **BL2600** folder provides sample programs specific to the BL2600. Each sample program has comments that describe the purpose and function of the program. Follow the instructions at the beginning of the sample program.

To run a sample program, open it with the **File** menu (if it is not still open), then compile and run it by pressing **F9**. The BL2600 must be in **Program** mode (see Section 3.7, “Serial Programming Cable,”) and must be connected to a PC using the programming cable as described in Section 2.2, “BL2600 Connections.”

More complete information on Dynamic C is provided in the *Dynamic C User’s Manual*. TCP/IP specific functions are described in the *Dynamic C TCP/IP User’s Manual*. Information on using the TCP/IP features and sample programs is provided in Section 5, “Using the TCP/IP Features.”

4.2.1 General BL2600 Sample Programs

The following sample programs are found in the **SAMPLES\BL2600** folder.

- **BOARD_ID.C**—This program is used to identify the model of BL2600 being used, and displays that information in the **STDIO** window.

4.2.2 Digital I/O

The following sample programs are found in the **IO** subdirectory in **SAMPLES\BL2600**.

- **DIGIN.C**—Demonstrates the use of the digital inputs. Using the Demonstration Board, you can see an input channel toggle from HIGH to LOW when pressing a pushbutton on the Demonstration Board. See Appendix C for hookup instructions for the Demonstration Board. This sample program does not explicitly configure any of the configurable I/O, so all the configurable I/O are available by default as digital inputs.
- **DIGIN_BANK.C**—Demonstrates the use of **digInBank** to read digital inputs. Using the Demonstration Board, you can see an input channel toggle from HIGH to LOW when pressing a pushbutton on the Demonstration Board. See Appendix C for hookup instructions for the Demonstration Board. This sample program does not explicitly configure any of the configurable I/O, so all the configurable I/O are available by default as digital inputs.
- **DIGOUT.C**—Demonstrates the use of the configurable I/O sinking outputs. Using the Demonstration Board, you can see an LED toggle on/off via a sinking output. See Appendix C for hookup instructions for the Demonstration Board.
- **DIGOUT_BANK.C**—Demonstrates the use of **digInBank** to control the configurable I/O sinking outputs. Using the Demonstration Board, you can see an LED toggle on/off via a sinking output. See Appendix C for hookup instructions for the Demonstration Board.

- **HIGH_CURRENT_IO.C**—Demonstrates the use of the high-current outputs configured as either sinking or sourcing outputs. High-current output HOUT0 is configured for sourcing to provide power to the Demonstration Board. Outputs HOUT1 and HOUT2 are configured to demonstrate tristate operation to toggle the LEDs on the Demonstration Board. Output HOUT3 is configured as a sinking output to toggle an LED on the Demonstration Board. See Appendix C for hookup instructions for the Demonstration Board.
- **PWM.C**—Demonstrates the use of the four PWM channels on Parallel Port F (PF4–PF7) on pins DIN20–DIN23. The PWM signals are set for a frequency of 10 kHz with the duty cycle adjustable from 1 to 99% by the user. Follow these instructions when running this sample program.

1. Connect the jumper across pins 7–8 on header JP4 to select the GND option.
2. Once you have compiled and run this program, you may change duty cycle for a given PWM channel via the Dynamic C **STDIO** window and use either an oscilloscope or a voltmeter to view the output. When monitoring with a voltmeter, you can compute the expected voltage

$$V_{out} = \text{PWM percentage} \times 1.65 \text{ V}$$

since the output voltage swing is from 0 V to 1.65 V DC.

4.2.3 Serial Communication

The following sample programs are found in the **RS232** subdirectory in **SAMPLES\BL2600**.

- **PARITY.C**—This sample program repeatedly sends byte values 0–127 from Serial Port F to Serial Port C. The program switches between generating parity and not generating parity on Serial Port F. Serial Port C will always be checking parity, so parity errors should occur during every other sequence. The results are displayed in the Dynamic C **STDIO** window.

Connect TxF to Rx C before compiling and running this sample program.

NOTE: For the sequence that does yield parity errors, the errors won't occur for each byte received. This is because certain byte patterns along with the stop bit will appear to generate the correct parity for the UART.

- **SIMPLE3WIRE.C**—This program demonstrates basic RS-232 serial communication. Connect TxC to Rx F on header J17 and connect TxF to Rx C on header J17 before compiling and running this sample program.
- **SIMPLE5WIRE.C**—This program demonstrates 5-wire RS-232 serial communication. Connect TxC to Rx C on header J17 and connect TxF to Rx F on header J17 before compiling and running this sample program.

TxF and Rx F become the flow control RTS and CTS. To test flow control, disconnect RTS from CTS while running this program. Characters should stop printing in the Dynamic C **STDIO** window and should resume when RTS and CTS are connected again

The following sample programs are found in the **RS485** subdirectory in **SAMPLES\BL2600**.

- **MASTER.C**—This program demonstrates a simple RS-485 transmission of lower case letters to a slave. The slave will send back converted upper case letters back to the master BL2600 and display them in the **STDIO** window. Use **SLAVE.C** to program the slave. Make the following connections between the master and slave:

485+ to 485+
485- to 485-
GND to GND

- **SLAVE.C**—This program demonstrates a simple RS-485 transmission of lower case letters to a slave. The slave will send back converted upper case letters back to the master BL2600 and display them in the **STDIO** window. Use **MASTER.C** to program the master BL2600.

4.2.4 A/D Converter Inputs

The following sample programs are found in the **ADC** subdirectory in **SAMPLES\BL2600**.

NOTE: The calibration sample programs will overwrite the calibration constants set at the factory.

- **ADC_CAL_DIFF.C**—Demonstrates how to recalibrate a differential A/D converter channel using two known voltages to generate two coefficients, gain and offset, which are rewritten into the reserved EEPROM. The voltage that is being monitored is displayed continuously.
- **ADC_CAL_MA.C**—Demonstrates how to recalibrate a milli-amp A/D converter channel using two known currents to generate two coefficients, gain and offset, which are rewritten into the reserved EEPROM. The current that is being monitored is displayed continuously.
- **ADC_CAL_SE_BIPOLAR.C**—Demonstrates how to recalibrate a single-ended bipolar A/D converter channel using two known voltages to generate two coefficients, gain and offset, which are rewritten into the reserved EEPROM. The voltage that is being monitored is displayed continuously.
- **ADC_CAL_SE_UNIPOLAR.C**—Demonstrates how to recalibrate a single-ended unipolar A/D converter channel using two known voltages to generate two coefficients, gain and offset, which are rewritten into the reserved EEPROM. The voltage that is being monitored is displayed continuously.
- **ADC_RD_CALDATA.C**—Demonstrates how to display the two calibration coefficients, gain and offset, in the Dynamic C **STDIO** window for each channel and mode of operation.
- **AD_RD_DIFF.C**—Demonstrates how to read and display voltage and equivalent values for a differential A/D converter channel using calibration coefficients previously stored in the EEPROM. The user selects to display either the raw data or the voltage equivalent.
- **AD_RD_MA.C**—Demonstrates how to read and display voltage and equivalent values for a milli-amp A/D converter channel using calibration coefficients previously stored in the EEPROM. The user selects to display either the raw data or the current equivalent.

- **AD_RD_SE_BIPOLAR.C**—Demonstrates how to read and display the voltage of all single-ended A/D converter channels using calibration coefficients previously stored in the EEPROM.
- **AD_RD_SE_UNIPOLAR.C**—Demonstrates how to read and display the voltage of all single-ended A/D converter channels using calibration coefficients previously stored in the EEPROM.

4.2.5 D/A Converter Outputs

The following sample programs are found in the **SAMPLES\BL2600\DAC** subdirectory.

NOTE: The calibration sample programs will overwrite the calibration constants set at the factory.

- **DAC_CAL_MA.C**—Demonstrates how to recalibrate a D/A converter channel using a known current to generate calibration constants, which are written into the reserved EEPROM.
- **DAC_CAL_VOLTS.C**—Demonstrates how to recalibrate a D/A converter channel using a known voltage to generate calibration constants, which are written into the reserved EEPROM.
- **DAC_MA_ASYNC.C**—Demonstrates how to output a current that can be read with an ammeter. The output current is computed with using the calibration constants that are stored in the reserved EEPROM.

The D/A converter circuit is set up for asynchronous operation, which updates the D/A converter output at the time it's being written via the **anaOut** or **anaOutmAmps** function calls.

- **DAC_MA_SYNC.C**—Demonstrates how to output a current that can be read with an ammeter. The output current is computed with using the calibration constants that are stored in the reserved EEPROM.

The D/A converter circuit is set up for synchronous operation, which updates the D/A converter output when the **anaOutStrobe** function call executes. The outputs will be updated with values previously written via the **anaOut** or **anaOutmAmps** function calls.

- **DAC_RD_CALDATA.C**—Demonstrates how to display the calibration coefficients, gain and offset, in the Dynamic C **STUDIO** window for each channel and mode of operation.
- **DAC_VOLT_ASYNC.C**—Demonstrates how to output a voltage that can be read with a voltmeter. The output voltage is computed with using the calibration constants that are stored in the reserved EEPROM.

The D/A converter circuit is set up for asynchronous operation, which updates the D/A converter output at the time it's being written via the **anaOut** or **anaOutVolts** function calls.

- **DAC_VOLT_SYNC.C**—Demonstrates how to output a voltage that can be read with a voltmeter. The output voltage is computed with using the calibration constants that are stored in the reserved EEPROM.

The D/A converter circuit is set up for synchronous operation, which updates the D/A converter output when the `anaOutStrobe` function call executes. The outputs will be updated with values previously written via the `anaOut` or `anaOutVolts` function calls.

4.2.6 Use of BL2600 with SF1000 Serial Flash Card

The following sample programs found in the `SAMPLES\BL2600\SF1000` folder demonstrate the use of the optional SF1000 serial flash card on the BL2600. The *SF1000 User's Manual* contains additional information and function calls for the SF1000.

- **FLASH_PATTERN_INSPECT.C**—Writes a pattern to the first 100 sectors of the SF1000, which can then be inspected or cleared by the user. The user then has the option to either inspect or clear a page of serial flash memory.
- **SFLASH_TEST.C**—Demonstrates how to read and write data from/to the SF1000. Once the sample program is compiled and run, it displays a message in the Dynamic C **STDIO** window to report whether the test was successful.

4.2.7 Use of NAND Flash

The following sample programs can be found in the `SAMPLES\BL2600\NANDFlash` folder.

- **NFLASH_DUMP.C**—This program is a utility for dumping the nonerased contents of a NAND flash chip to the Dynamic C **STDIO** window, and the contents may be redirected to a serial port.

When the sample program starts running, it attempts to initialize the user-selected NAND flash chip. If the initialization is successful and the main page size is acceptable, the nonerased page contents (non 0xFF) from the NAND flash page are dumped to the Dynamic C **STDIO** win. for inspection.

Note that an error message will appear when the first 32 pages (0x20 pages) are “dumped.” You may ignore the error message.

- **NFLASH_INSPECT.C**—This program is a utility for inspecting the contents of a NAND flash chip. When the sample program starts running, it attempts to initialize the NAND flash chip selected by the user. Once a NAND flash chip is found, the user can execute various commands to print out the contents of a specified page, clear (set to zero) all the bytes in a specified page, erase, or write to specified pages.

CAUTION: When you run this sample program, enabling the `#define NFLASH_CANERASEBADBLOCKS` macro makes it possible to write to bad blocks. The first two blocks on the memory card are marked bad to protect the configuration data needed to use the card in a digital camera or PC. You will only be able to use the memory card in Rabbit-based systems if either of the first two blocks is written to.

- **NFLASH_LOG.C**—This program runs a simple Web server and stores a log of hits in the NAND flash. This log can be viewed and cleared from a browser.

- **NFLASH_ERASE.C**—This program is a utility to erase all the good blocks on a NAND flash chip. When the program starts running, it attempts to initialize the NAND flash chip selected by the user. If the initialization is successful, the progress in erasing the blocks is displayed in the Dynamic C **STDIO** window.

4.2.8 Real-Time Clock

If you plan to use the real-time clock functionality in your application, you will need to set the real-time clock. You may set the real-time clock using the **SETRTCKB.C** sample program from the Dynamic C **SAMPLES\RTCLOCK** folder. The **RTC_TEST.C** sample program in the Dynamic C **SAMPLES\RTCLOCK** folder provides additional examples of how to read and set the real-time clock

4.2.9 TCP/IP Sample Programs

TCP/IP sample programs are described in Chapter 5.

4.3 BL2600 Libraries

Two library directories provide libraries of function calls that are used to develop applications for the BL2600.

- **BL2600**—libraries associated with features specific to the BL2600. The functions in the **BL26xx.LIB** library are described in Section 4.4, “BL2600 Function Calls.”
- **RN_CFG_BL26.LIB**—used to configure the BL2600 for use with RabbitNet peripheral boards.
- **TCP/IP**—libraries specific to using TCP/IP functions on the BL2600. Further information about TCP/IP is provided in Chapter 5, “Using the TCP/IP Features.”

4.4 BL2600 Function Calls

4.4.1 Board Initialization

```
void brdInit (void);
```

Call this function at the beginning of your program. This function initializes the system I/O ports and loads all the A/D converter and D/A converter calibration constants from flash memory into SRAM for use by your program.

The ports are initialized according to Table A-3 in Appendix A.

SEE ALSO

digOut, digIn, serMode, anaOut, anaIn, anaInDriver, anaOutDriver

4.4.2 Digital I/O

```
void digHoutConfig(char configuration);
```

Configures a high-current output to be either a sinking or a sourcing output. This configuration information is also used to initially set the output to the off state for the given hardware output configuration. The configuration options are described below.

NOTE: Configuring a given output channel for tristate operation using the `digHTriStateConfig` function will override the configuration set by the `digHoutConfig` function.

NOTE: The `brdInit` function must be executed before calling `digHoutConfig`.

NOTE: You must execute the `digHoutConfig` function to set the high-current drivers to be either sinking or sourcing. A runtime error will occur in `digHout` if `digHoutConfig` has not executed.

NOTE: The extra digital outputs resulting from the configuration of DIO00–DIO15 as digital outputs are sinking outputs only and cannot be configured with `digHoutConfig`.

PARAMETER

`configuration` is a 1-byte parameter where 4 bits are used for the high-current outputs HOUT0–HOUT3.

Bit 3 = high-current output channel HOUT3
Bit 2 = high-current output channel HOUT2
Bit 1 = high-current output channel HOUT1
Bit 0 = high-current output channel HOUT0
(bits 4–7 are not used)

The high-current outputs can be configured to be sinking or sourcing outputs by setting the corresponding bit to an 0 or 1: 0 = sinking, 1 = sourcing.

RETURN VALUE

None.

SEE ALSO

`brdInit`, `digHout`, `digHTriStateConfig`, `digHoutTriState`

EXAMPLE

```
configuration = 0x0C
0x06 = 00001100 (bits 7–0)
HOUT3 is sourcing
HOUT2 is sourcing
HOUT1 is sinking
HOUT0 is sinking
```

```
void digHout(int channel, int state);
```

Sets the state of a high-current digital output (HOUT0–HOUT3) to a logic 0, logic 1, or high impedance.

Remember to call the `brdInit` and the `digHoutConfig` functions before executing this function.

A runtime error will occur for the following conditions:

1. `channel` or `state` out of range.
2. `brdInit` or `digHoutConfig` was not executed before executing `digHout`.
3. If you try to use a channel that is configured as a tristate output by `digHTriStateConfig`.

PARAMETERS

`channel` is the output channel number (0–3).

`state` sets a given channel to one of the following output states depending on how the output was configured by `digHoutConfig`.

Sinking configuration:

- 0 = connect the load to GND
- 1 = put the output in a high-impedance state

Sourcing configuration:

- 0 = put the output in a high-impedance state
- 1 = connects the load to +K(0–3)

RETURN VALUE

None.

SEE ALSO

`brdInit`, `digHoutConfig`, `digHoutTriState`, `digOut`

```
void digHTriStateConfig(char configuration);
```

Configures whether a high-current output is a tristate type output. This configuration information is also used to initially set the output to the off state for the given hardware output configuration. The configuration options are described below.

PARAMETER

configuration is a 1-byte parameter where 4 bits are used for the high-current outputs HOUT0–HOUT3.

- Bit 3 = high-current output channel HOUT3
- Bit 2 = high-current output channel HOUT2
- Bit 1 = high-current output channel HOUT1
- Bit 0 = high-current output channel HOUT0

(bits 4–7 are not used)

The high-current outputs can be configured as tristate outputs by setting the corresponding bit to a 0 or 1: 0 = disable operation as tristate output, 1 = enable operation as tristate output.

RETURN VALUE

None.

SEE ALSO

`brdInit`, `digHout`, `dgigHoutConfig`, `digHoutTriState`

EXAMPLE

```
configuration = 0x09
```

0x09 = 00001001 (remember these bits are bits 7–0)

- HOUT3 tristate output is enabled
- HOUT2 tristate output is disabled
- HOUT1 tristate output is disabled
- HOUT0 tristate output is enabled

```
void digHoutTriState(int channel, int state);
```

Sets the state of a high-current digital output (HOUT0–HOUT3) to a logic 0, logic 1, or high impedance.

Remember to call the **brdInit** and the **digHTriStateConfig** functions before executing this function.

A runtime error will occur for the following conditions:

1. **channel** or **state** out of range.
2. **brdInit** or **digHTriStateConfig** was not executed before executing **digHoutTriState**.
3. If you try to use a channel that is not configured as a tristate output by **digHTriStateConfig**.

PARAMETERS

channel is the output channel number (0–3).

state sets a given channel to one of the following output states depending on how the output was configured by **digHTriStateConfig**.

Tristate configuration:

- 0 = connect the load to GND
- 1 = connects the load to +K(0–3)
- 2 = put the output in a high-impedance state

RETURN VALUE

None.

SEE ALSO

brdInit, **digHout**, **digHoutConfig**, **digHTriStateConfig**

```
void digOutConfig(int configuration);
```

Configures any of the 16 configurable I/O channels to be a sinking output. This configuration information is then used by the **digOut** function to determine whether a given channel is configured to be an output. If it is not, **digOut** will prevent the given channel from being used by the **digOut** function. The configuration options are described below.

PARAMETER

configuration is a 16-bit parameter for which each bit corresponds to a configurable I/O channel (0–15). An output channel is enabled by setting the corresponding bit number to a logic one.

- Bit 15 = output channel DIO15
- Bit 14 = output channel DIO14
- Bit 13 = output channel DIO13
- Bit 12 = output channel DIO12
- Bit 11 = output channel DIO11
- Bit 10 = output channel DIO10
- Bit 9 = output channel DIO09
- Bit 8 = output channel DIO08
- Bit 7 = output channel DIO07
- Bit 6 = output channel DIO06
- Bit 5 = output channel DIO05
- Bit 4 = output channel DIO04
- Bit 3 = output channel DIO03
- Bit 2 = output channel DIO02
- Bit 1 = output channel DIO01
- Bit 0 = output channel DIO00

The configurable I/O are configured to be sinking by setting the corresponding bit to 1; setting the bit to 0 disables that channel for output operation.

RETURN VALUE

None.

SEE ALSO

brdInit, digHout, dgigHoutConfig, digHoutTriState

EXAMPLE

```
configuration = 0x8005
```

0x8005 = 100000000000101 (bits 15–0)

DIO15, DIO02, and DIO00 have been enabled for use as sinking outputs. The remaining configurable I/O are locked out from being used by the **digOut** function.

```
void digOut(int channel, int state);
```

Sets the state of a configurable I/O channel (DIO00–DIO15) configured as a sinking digital output to a logic 0 or a logic 1. This function only allows control of channels that are configured to be an output by the **digOutConfig** function.

Remember to call the **brdInit** and the **digOutConfig** functions before executing this function.

A runtime error will occur for the following conditions:

1. **channel** or **state** out of range.
2. **brdInit** or **digOutConfig** was not executed before executing **digOut**.
3. If you try to use a channel that is not configured as a digital output by **digOutConfig**.

PARAMETERS

channel is the output channel number (0–15).

state sets a given channel to one of the following output states.

0 = connect the load to GND

1 = put the output in a high-impedance state

RETURN VALUE

None.

SEE ALSO

brdInit, **digHout**, **digOutConfig**, **digBankOut**, **digIn**

```
void digOutBank(char bank, char data);
```

Sets the state of a bank of configurable I/O channels (DIO00–DIO15) configured as sinking digital outputs to a logic 0 or a logic 1. This function only allows control of channels that are configured to be an output by the `digOutConfig` function.

Remember to call the `brdInit` and the `digOutConfig` functions before executing this function.

A runtime error will occur for the following conditions:

1. `bank` is out of range.
2. `brdInit` or `digOutConfig` was not executed before executing `digOutBank`.

PARAMETERS

`bank` is 0 or 1.

0 = DIO00–DIO07

1 = DIO08–DIO15

`data` is a value to be written to the specified digital output bank. The data format and bitwise value are as follows.

Data Format

Data	D7	D6	D5	D4	D3	D2	D1	D0
Bank 0	DIO07	DIO06	DIO05	DIO04	DIO03	DIO02	DIO01	DIO00
Bank 1	DIO15	DIO14	DIO13	DIO12	DIO11	DIO10	DIO09	DIO08

0 = connect the load to GND

1 = put the output in a high-impedance state

RETURN VALUE

None.

SEE ALSO

`brdInit`, `digHout`, `digOutConfig`, `digBankOut`, `digIn`

int digIn(int channel);

Reads the state of a digital input channel. If a configurable I/O channel (DIO00–DIO15) that was configured as a digital output is read by **digIn**, then the value read will be the state of the output channel.

A run-time error will occur for the following conditions:

1. **channel** out of range.
2. **brdInit** was not executed before executing **digIn**.

PARAMETER

channel is the input channel number (0–15 for DIO00–DIO15, 16–31 for IN16–IN31).

RETURN VALUE

The logic state of the specified channel (0 = low or 1 = high).

SEE ALSO

brdInit, **digOut**, **digOutConfig**, **digInBank**

char digInBank(int bank);

Reads the state of a bank of 8 digital input channels. If a configurable I/O channel (DIO00–DIO15) that was configured as a digital output is read by **digInBank**, then the value returned will be the state of the output channel.

A run-time error will occur for the following conditions:

1. **bank** out of range.
2. **brdInit** was not executed before executing **digInBank**.

PARAMETER

bank is the bank of digital input channels to read.

- 0 = DIO00–DIO07 (bank 0)
- 1 = DIO08–DIO15 (bank 1)
- 2 = IN16–IN23 (bank 2)
- 3 = IN24–IN31 (bank 3)

RETURN VALUE

The logic state of each channel in the specified bank (0 = low or 1 = high). The data is returned as a byte, with each bit representing the state of a particular channel in the bank ordered from the most significant bit to the least significant bit.

SEE ALSO

brdInit, **digOut**, **digOutConfig**, **digInBank**

4.4.3 Serial Communication

Library files included with Dynamic C provide a full range of serial communications support. The **RS232.LIB** library provides a set of circular-buffer-based serial functions. The **PACKET.LIB** library provides packet-based serial functions where packets can be delimited by the 9th bit, by transmission gaps, or with user-defined special characters. Both libraries provide blocking functions, which do not return until they are finished transmitting or receiving, and nonblocking functions, which must be called repeatedly until they are finished. For more information, see the *Dynamic C User's Manual* and Technical Note 213, *Rabbit Serial Port Software*.

Use the following function calls with the BL2600.

```
int serMode(int mode);
```

User interface to set up BL2600 serial communication lines. Call this function after **serXOpen()**.

Whether you are opening one or multiple serial ports, this function must be executed after executing the last **serXOpen** function AND before you start using any of the serial ports. This function is non-reentrant.

If Mode 1 is selected, CTS/RTS flow control is exercised using the **serCflowcontrolOn** and **serCflowcontrolOff** functions from the **RS232.LIB** library.

PARAMETER

mode is the defined serial port configuration.

Mode	Serial Port		
	C	F	E
0	RS-232, 3-wire	RS-232, 3-wire	RS-232, 3-wire
1	RS-232, 3-wire	RS-232, 3-wire	RS-485
2	RS-232, 5-wire	RTS/CTS	RS-232, 3-wire
3	RS-232, 5-wire	RTS/CTS	RS-485

RETURN VALUE

0 if valid mode selected, 1 if not.

SEE ALSO

brdInit, **ser485Tx**, **ser485Rx**

void ser485Tx(void);

Enables the RS-485 transmitter. **serMode** must be executed before running this function.

NOTE: Transmitted data are echoed back into the receive data buffer. The echoed data could be used to identify when to disable the transmitter by using one of the following methods.

Byte mode—disables the transmitter after the byte that is transmitted is detected in the receive data buffer.

Block data mode—disable the transmitter after the same number of bytes transmitted are detected in the receive data buffer.

RETURN VALUE

None.

SEE ALSO

brdInit, serMode, ser485Rx

void ser485Rx(void);

Disables the RS-485 transmitter. This puts you in listen mode, which allows you to receive data from the RS-485 interface. **serMode** must be executed before running this function.

RETURN VALUE

None.

SEE ALSO

brdInit, serMode, ser485Tx

4.4.4 A/D Converter Inputs

```
void anaInConfig(int ch_pair, int opmode);
```

Configures an A/D converter input channel pair for a given mode of operation. This function must be called before accessing the A/D converter chip.

NOTE: If you plan to configure the D/A converter chip using **anaOutConfig**, you must call **anaOutConfig** before executing **anaInConfig**. This is because the A/D converter uses internal channels 4–7 on the D/A converter chip to bias the A/D converter input circuit.

PARAMETERS

ch_pair are the channel pairs:

- 0 = channels 0 and 1
- 1 = channels 2 and 3
- 2 = channels 4 and 5
- 3 = channels 6 and 7

opmode selects the mode of operation for the channel pair on A/D converter:

- 0 = Single-Ended unipolar (0–10 V)
- 1 = Single-Ended bipolar (± 10 V)
- 2 = Differential bipolar (± 20 V)
- 3 = 4–20 mA

RETURN VALUE

None.

SEE ALSO

brdInit, **anaInCalib**, **anaInDriver**, **anaIn**, **anaInVolts**, **anaInmAmps**, **anaInDiff**

```
int anaInCalib(int channel, int opmode,
               int gaincode, int value1, float volts1,
               int value2, float volts2);
```

Calibrates the response of a given A/D converter channel as a linear function using the two conversion points provided. Gain and offset constants are calculated and placed into global table `_adcInCalib`.

PARAMETERS

channel is the analog input channel number (0 to 7) corresponding to AIN0–AIN7

channel	Single-Ended	Differential	4–20 mA
0	+AIN0	+AIN0 -AIN1	+AIN0
1	+AIN1	—	+AIN1
2	+AIN2	+AIN2 -AIN3	+AIN2
3	+AIN3	—	+AIN3
4	+AIN4	+AIN4 -AIN5	
5	+AIN5	—	
6	+AIN6	+AIN6 -AIN7	
7	+AIN7	—	

opmode is the mode of operation for the specified channel. Use one of the following macros to set the mode for the channel being configured.

- 0 = Single-Ended unipolar (0–20 V)
- 1 = Single-Ended bipolar (± 10 V)
- 2 = Differential bipolar (± 20 V)
- 3 = 4–20 mA

gaincode is the gain code of 0 to 7 (use a gain code of 4 for 4–20 mA operation)

Gain Code	Macro	Voltage Range		
		Single-Ended Unipolar	Single-Ended Bipolar	Differential Bipolar
0	GAIN_X1	0–20 V	± 10 V	± 20 V
1	GAIN_X2	0–10 V	± 5 V	± 10 V
2	GAIN_X4	0–5 V	± 2.5 V	± 5 V
3	GAIN_X5	0–4 V	± 2 V	± 4 V
4	GAIN_X8	0–2.5 V	± 1.25 V	± 2.5 V
5	GAIN_X10	0–2 V	± 1 V	± 2 V
6	GAIN_X16	0–1.25 V	—	± 1.25 V
7	GAIN_X20	0–1 V	—	± 1 V

value1 is the first A/D converter value (0–4095).

volts1 is the voltage corresponding to the first A/D converter value.

value2 is the second A/D converter value (0–4095).

volts2 is the voltage corresponding to the second A/D converter value.

NOTE: The 10 and 90% points of the maximum voltage range are recommended when calibrating a channel.

RETURN VALUE

0 if successful.

-1 if not able to make calibration constants.

SEE ALSO

`brdInit`, `anaInConfig`, `anaIn`, `anaInmAmps`, `anaInDiff`, `anaInVolts`

```
int anaIn(int channel, int gaincode);
```

Reads the state of an A/D converter input channel. If the access is for an A/D converter single-ended bipolar channel and the gain code for the given channel has changed from the previous cycle, the EEPROM will be read to get the calibration constants for the new gain value.

PARAMETER

channel is the analog input channel number (0 to 7) corresponding to AIN0–AIN7

channel	Single-Ended	Differential	4–20 mA
0	+AIN0	+AIN0 -AIN1	+AIN0
1	+AIN1	—	+AIN1
2	+AIN2	+AIN2 -AIN3	+AIN2
3	+AIN3	—	+AIN3
4	+AIN4	+AIN4 -AIN5	
5	+AIN5	—	
6	+AIN6	+AIN6 -AIN7	
7	+AIN7	—	

gaincode is the gain code of 0 to 7 (use a gain code of 4 for 4–20 mA operation)

Gain Code	Macro	Voltage Range		
		Single-Ended Unipolar	Single-Ended Bipolar	Differential Bipolar
0	GAIN_X1	0–20 V	±10 V	± 20 V
1	GAIN_X2	0–10 V	±5 V	± 10 V
2	GAIN_X4	0–5 V	±2.5 V	± 5 V
3	GAIN_X5	0–4 V	±2 V	± 4 V
4	GAIN_X8	0–2.5 V	±1.25 V	± 2.5 V
5	GAIN_X10	0–2 V	±1 V	± 2 V
6	GAIN_X16	0–1.25 V	—	± 1.25 V
7	GAIN_X20	0–1 V	—	± 1 V

RETURN VALUE

A value corresponding to the voltage or current on the analog input channel (0–2047 for 11-bit conversions).

SEE ALSO

brdInit, *anaInConfig*, *anaInCalib*, *anaInmAmps*, *anaInDiff*, *anaInVolts*

```
float anaInVolts(int channel, int gaincode);
```

Reads the state of a single-ended A/D converter input channel and uses the previously set calibration constants to convert it to volts.

If the gain code for a given channel has changed from the previous cycle, the following code accesses will occur.

1. The EEPROM will be read to get the calibration constants for the new gain value.
2. The D/A converter will be written to bias the A/D converter input circuit for proper operation. (The D/A converter access only applies for the single-ended bipolar A/D converter operation.)

PARAMETER

channel is the A/D converter input channel (0–7).

gaincode is the gain code of 0 to 7.

RETURN VALUE

A voltage value corresponding to the voltage on the analog input channel. A value of -4096 indicates an overflow or out-of-range condition.

SEE ALSO

brdInit, anaInConfig, anaIn, anaInmAmps, anaInDiff, anaInCalib

```
float anaInDiff(int channel, int gaincode);
```

Reads the state of a differential A/D converter input channel and uses the previously set calibration constants to convert it to volts. If the gain code for a given channel has changed from the previous cycle, the EEPROM will be read to get the calibration constants for the new gain value.

PARAMETER

channel is the analog input channel number (0, 2, 4, 6) as shown below

channel	Differential Inputs
0	+AIN0 -AIN1
2	+AIN2 -AIN3
4	+AIN4 -AIN5
6	+AIN6 -AIN7

gaincode is the gain code of 0 to 7

Gain Code	Macro	Actual Gain	Differential Voltage Range
0	GAIN_X1	×1	± 20 V
1	GAIN_X2	×2	± 10 V
2	GAIN_X4	×4	± 5 V
3	GAIN_X5	×5	± 4 V
4	GAIN_X8	×8	± 2.5 V
5	GAIN_X10	×10	± 2 V
6	GAIN_X16	×16	± 1.25 V
7	GAIN_X20	×20	± 1 V

RETURN VALUE

A voltage value corresponding to the voltage on the analog input channel. A value of -4096 indicates an overflow or out-of-range condition.

SEE ALSO

`brdInit`, `anaInConfig`, `anaIn`, `anaInmAmps`, `anaInVolts`, `anaInCalib`

```
float anaInmAmps(int channel);
```

Reads the state of a single-ended A/D converter input channel and uses the previously set calibration constants to convert it to the current value.

PARAMETER

channel is the A/D converter input channel (0–3 corresponding to AIN0–AIN3).

RETURN VALUE

A current value corresponding to the current on the analog input channel with a range of 4–20 mA. A value of -4096 indicates an overflow or out-of-range condition.

SEE ALSO

`brdInit`, `anaInConfig`, `anaIn`, `anaInDiff`, `anaInVolts`, `anaInCalib`

4.4.5 D/A Converter Outputs

```
int anaOutConfig(char configuration, int mode);
```

Configures the D/A converter chip for a given output voltage range, 0–10 V or ± 10 V, and loads the calibration data for use by the D/A converter API functions. This function must be called before accessing any of the D/A converter channels.

NOTE: If you are using the analog outputs, you must configure the D/A converter chip using the `anaOutConfig` function before executing `anaInConfig` to configure the A/D converter chip. This is because the A/D converter chip uses internal channels 4–7 on the D/A converter chip to bias the A/D converter input circuit, and the correct configuration of the A/D converter would be affected if the D/A converter configuration was changed later.

PARAMETERS

`configuration` sets the output configuration as follows:

0 = unipolar operation. (0–10V and 4–20 mA)

1 = bipolar operation. (± 10 V and 4–20 mA)

NOTE: When the D/A converter is configured for bipolar operation, the 4–20 mA channels change from 12-bit to 11-bit resolution.

`mode` is the mode of operation:

0 = asynchronous—an output is updated at the time data are written to the given channel

1 = synchronous—all outputs are updated with data previously written when the `anaOutStrobe` function is executed.

RETURN VALUE

None.

SEE ALSO

`brdInit`, `anaOut`, `anaOutmAmps`, `anaOutStrobe`, `anaOutConfig`, `anaOutCalib`

```
int anaOutCalib(int channel, int calib_index,  
int value1, float volts1, int value2,  
float volts2);
```

Calibrates the response of a given D/A converter channel as a linear function with using two conversion points provided by the user. Gain and offset constants are calculated and written to the EEPROM for use by the D/A converter API functions.

PARAMETERS

channel is the D/A converter output channel (0–3).

calib_index is an index used to go to the proper location in the lookup table for writing the calibration data:

- 0 = 0–10 V calibration data
- 1 = ±10 V calibration data
- 2 = 4–20 mA calibration data (unipolar configuration)
- 3 = 4–20 mA calibration data (bipolar configuration)

value1 is the first D/A converter value (0–4095).

volts1 is the voltage or current corresponding to the first D/A converter value (0–10 V, ±10 V or 4–20 mA).

value2 is the second D/A converter value (0–4095).

volts2 is the voltage or current corresponding to the second D/A converter value (0–10 V, ±10 V or 4–20 mA).

NOTE: The 10 and 90% points of the maximum voltage range are recommended when calibrating a channel.

RETURN VALUE

0 if successful.

-1 if not able to make calibration constants.

SEE ALSO

`brdInit`, `anaOut`, `anaOutVolts`, `anaOutmAmps`, `anaOutStrobe`, `anaOutConfig`

```
void anaOutStrobe(void);
```

Strobes the D/A converter chip, which will update all the outputs with the previously written values (or default value of zero).

This function is only valid if the D/A converter chip has been configured for synchronous operation using the `anaOutConfig` function.

RETURN VALUE

None.

SEE ALSO

`brdInit`, `anaOut`, `anaOutmAmps`, `anaOutStrobe`, `anaOutConfig`, `anaOutCalib`

```
void anaOutPwr(int control);
```

Enables or disables the BL2600 power supply used to drive the D/A converter output voltage or current circuits.

NOTE: Call this function only after you have configured all the D/A converter output channels to the desired voltage or current. Unconfigured D/A converter channels, both voltage and 4–20 mA, will be set to approx. 0 V or 4 mA respectively.

PARAMETER

control sets whether the power supply is on or off:

0 = off

1 = on

RETURN VALUE

None.

SEE ALSO

`anaOutDisable`, `anaOut`, `anaOutVolts`, `anaOutmAmps`

```
void anaOut(int ch, int rawdata);
```

Sets the voltage of a D/A converter output channel.

PARAMETERS

`ch` is the D/A converter output channel (0–3).

`rawdata` is a data value corresponding to the voltage desired on the output channel (0–4095).

RETURN VALUE

0 if successful.

-1 if `rawcount` is more than 4095.

SEE ALSO

`anaOutDriver`, `anaOutVolts`, `anaOutCalib`

```
void anaOutVolts(int ch, float voltage);
```

Sets the voltage of a D/A converter output channel by using the previously set calibration constants to calculate the correct data values.

PARAMETERS

`ch` is the D/A converter output channel (0–3).

`voltage` is the voltage desired on the output channel.

RETURN VALUE

None.

SEE ALSO

`brdInit`, `anaOut`, `anaOutStrobe`, `anaOutConfig`, `anaOutCalib`

```
void anaOutmAmps(int ch, float current);
```

Sets the current of a D/A converter output channel by using the previously set calibration constants to calculate the correct data values.

PARAMETERS

ch is the D/A converter output channel (0–3).

current is the current desired on the output channel (the valid range is 4–20 mA).

RETURN VALUE

None.

SEE ALSO

`brdInit`, `anaOut`, `anaOutVolts`, `anaOutStrobe`, `anaOutConfig`, `anaOutCalib`

4.4.6 SRAM Use

The BL2600 model and some memory variations described in Section 1.2.2 have a battery-backed data SRAM and a program-execution SRAM. Dynamic C provides the **protected** keyword to identify variables that are to be placed into the battery-backed SRAM. The compiler generates code that maintains two copies of each protected variable in the battery-backed SRAM. The compiler also generates a flag to indicate which copy of the protected variable is valid at the current time. This flag is also stored in the battery-backed SRAM. When a protected variable is updated, the “inactive” copy is modified, and is made “active” only when the update is 100% complete. This assures the integrity of the data in case a reset or a power failure occurs during the update process. At power-on the application program uses the active copy of the variable pointed to by its associated flag.

The sample code below shows how a protected variable is defined and how its value can be restored.

```
protected nf_device nandFlash;
int main() {
    ...
    _sysIsSoftReset();    // restore any protected variables
```

The **bbram** keyword may also be used instead if there is a need to store a variable in battery-backed SRAM without affecting the performance of the application program. Data integrity is *not* assured when a reset or power failure occurs during the update process.

Additional information on **bbram** and **protected** variables is available in the *Dynamic C User's Manual*.

4.4.7 NAND Flash Drivers

The Dynamic C **NANDFlash\NFLASH.LIB** library is used to interface to NAND flash memory devices on the RCM3365 and the RCM3375. The function calls were written specifically to work with industry-standard flash devices with a 528-byte page program and 16896-byte block erase size. The NAND flash function calls are designed to be closely cross-compatible with the newer serial flash function calls found in the **SFLASH.LIB** library. These function calls use an **nf_device** structure as a handle for a specific NAND flash device. This allows multiple NAND flash devices to be used by an application.

More information on these function calls is available in the *Dynamic C Function Reference Manual*.

5. USING THE TCP/IP FEATURES

Chapter 5 discusses using the TCP/IP features on the BL2600 and BL2610 boards. The TCP/IP feature is *not* available on BL2610.

5.1 TCP/IP Connections

Before proceeding you will need to have the following items.

- If you don't have Ethernet access, you will need at least a 10Base-T Ethernet card (available from your favorite computer supplier) installed in a PC.
- Two RJ-45 straight-through CAT 5/6 Ethernet cables and a hub, or an RJ-45 crossover CAT 5/6 Ethernet cable.

The CAT 5/6 Ethernet cables and Ethernet hub are available from Rabbit in a TCP/IP tool kit. More information is available at www.rabbit.com.

1. Connect the AC adapter and the programming cable as shown in Chapter 2, "Getting Started."
2. Ethernet Connections

If you do not have access to an Ethernet network, use a crossover CAT 5/6 Ethernet cable to connect the BL2600 to a PC that at least has a 10Base-T Ethernet card.

If you have Ethernet access, use a straight-through CAT 5/6 Ethernet cable to establish an Ethernet connection to the BL2600 from an Ethernet hub. These connections are shown in Figure 23.

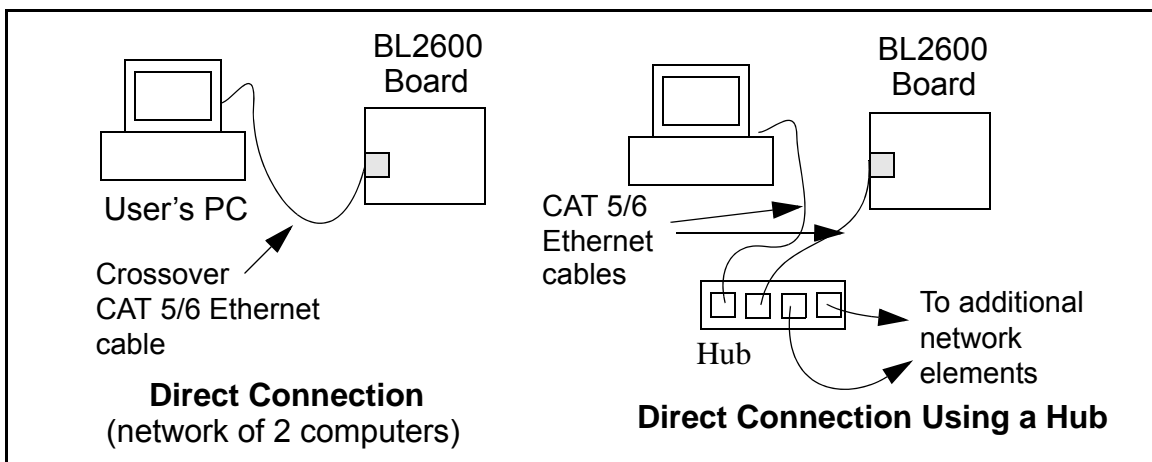

Figure 23. Ethernet Connections

The PC running Dynamic C through the serial programming port on the BL2600 does not need to be the PC with the Ethernet card.

3. Apply Power

Plug in the AC adapter. The BL2600 is now ready to be used.

NOTE: A hardware RESET is accomplished by unplugging the AC adapter, then plugging it back in, or by momentarily grounding the board reset input at pin 9 on screw terminal header J2.

When working with the BL2600, the green **LNK** light is on when a program is running and the board is properly connected either to an Ethernet hub or to an active Ethernet card. The orange **ACT** light flashes each time a packet is received.

5.2 TCP/IP Sample Programs

We have provided a number of sample programs demonstrating various uses of TCP/IP for networking embedded systems. These programs require that you connect your PC and the BL2600 together on the same network. This network can be a local private network (preferred for initial experimentation and debugging), or a connection via the Internet.

5.2.1 How to Set IP Addresses in the Sample Programs

With the introduction of Dynamic C 7.30 we have taken steps to make it easier to run many of our sample programs. You will see a **TCPCONFIG** macro. This macro tells Dynamic C to select your configuration from a list of default configurations. You will have three choices when you encounter a sample program with the **TCPCONFIG** macro.

1. You can replace the **TCPCONFIG** macro with individual **MY_IP_ADDRESS**, **MY_NETMASK**, **MY_GATEWAY**, and **MY_NAMESERVER** macros in each program.
2. You can leave **TCPCONFIG** at the usual default of 1, which will set the IP configurations to **10.10.6.100**, the netmask to **255.255.255.0**, and the nameserver and gateway to **10.10.6.1**. If you would like to change the default values, for example, to use an IP address of **10.1.1.2** for the BL2600 board, and **10.1.1.1** for your PC, you can edit the values in the section that directly follows the “General Configuration” comment in the **TCP_CONFIG.LIB** library. You will find this library in the **LIB\TCPIP** directory.
3. You can create a **CUSTOM_CONFIG.LIB** library and use a **TCPCONFIG** value greater than 100. Instructions for doing this are at the beginning of the **TCP_CONFIG.LIB** library in the **LIB\TCPIP** directory.

There are some other “standard” configurations for **TCPCONFIG** that let you select different features such as DHCP. Their values are documented at the top of the **TCP_CONFIG.LIB** library in the **LIB\TCPIP** directory. More information is available in the *Dynamic C TCP/IP User's Manual*.

5.2.2 How to Set Up your Computer's IP Address for a Direct Connection

When your computer is connected directly to the BL2600 via an Ethernet connection, you need to assign an IP address to your computer. To assign the PC the address **10.10.6.101** with the subnetmask **255.255.255.0**, do the following.

Click on **Start > Settings > Control Panel** to bring up the Control Panel, and then double-click the Network icon. Depending on which version of Windows you are using, look for the **TCP/IP Protocol/Network > Dial-Up Connections/Network** line or tab. Double-click on this line or select **Properties** or **Local Area Connections > Properties** to bring up the TCP/IP properties dialog box. You can edit the IP address and the subnet mask directly. (Disable “obtain an IP address automatically”.) You may want to write down the existing values in case you have to restore them later. It is not necessary to edit the gateway address since the gateway is not used with direct connect.

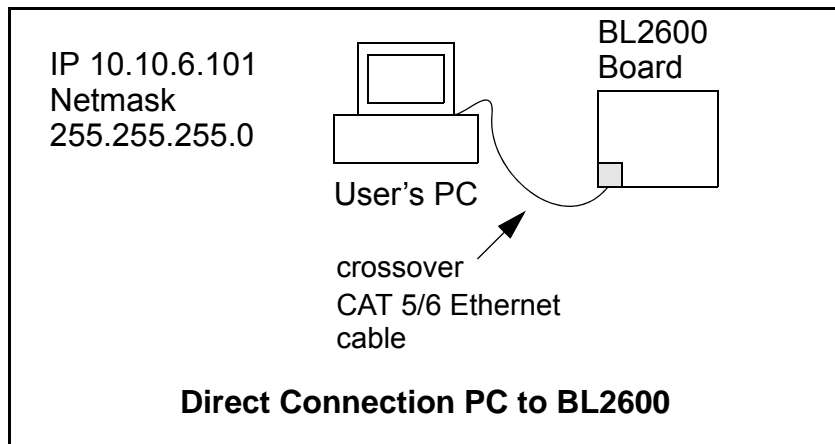

5.2.3 Run the PINGME.C Demo

Connect the crossover cable from your computer's Ethernet port to the BL2600's RJ-45 Ethernet connector. Open this sample program from the **SAMPLES\TCPIP\ICMP** folder, compile the program, and start it running under Dynamic C. When the program starts running, the green **LNK** light on the BL2600 should be on to indicate an Ethernet connection is made. (Note: If the **LNK** light does not light, you may not have a crossover cable, or if you are using a hub perhaps the power is off on the hub.)

The next step is to ping the board from your PC. This can be done by bringing up the MS-DOS window and running the ping program:

```
ping 10.10.6.100
```

or by **Start > Run**

and typing the command

```
ping 10.10.6.100
```

Notice that the orange **ACT** light flashes on the BL2600 while the ping is taking place, and indicates the transfer of data. The ping routine will ping the board four times and write a summary message on the screen describing the operation.

5.2.4 Running More Demo Programs With a Direct Connection

The program `SSI.C` (`SAMPLES\BL2600\TCPIP\`) demonstrates how to make the BL2600 a Web server. This program allows you to turn the LEDs on an attached Demonstration Board from the Tool Kit on and off from a remote Web browser. The LEDs on the Demonstration Board match the ones on the Web page. Follow the instructions included with the sample program. As long as you have not modified the `TCPCONFIG 1` macro in the sample program, enter the following server address in your Web browser to bring up the Web page served by the sample program.

`http://10.10.6.100.`

Otherwise use the TCP/IP settings you entered in the `TCP_CONFIG.LIB` library.

The sample program `SMTP.C` (`SAMPLES\BL2600\TCPIP\`) allows you to send an E-mail when a switch on the Demonstration Board is pressed. Follow the instructions included with the sample program.

The sample program `TELNET.C` (`SAMPLES\BL2600\TCPIP\`) allows you to communicate with the BL2600 using the Telnet protocol. This program takes anything that comes in on a port and sends it out Serial Port C. It uses a digital input to indicate that the TCP/IP connection should be closed and a digital output to toggle a LED to indicate that there is an active connection.

Follow the instructions included with the sample program. Run the Telnet program on your PC (**Start > Run telnet 10.10.6.100**). As long as you have not modified the `TCPCONFIG 1` macro in the sample program, the IP address is 10.10.6.100 as shown; otherwise use the TCP/IP settings you entered in the `TCP_CONFIG.LIB` library. Each character you type will be printed in Dynamic C's **STDIO** window, indicating that the board is receiving the characters typed via TCP/IP.

5.3 Where Do I Go From Here?

NOTE: If you purchased your BL2600 through a distributor or Rabbit partner, contact the distributor or partner first for technical support.

If there are any problems at this point:

- Use the Dynamic C **Help** menu to get further assistance with Dynamic C.
- Check the Rabbit Technical Bulletin Board and forums at www.rabbit.com/support/bb/ and at www.rabbit.com/forums/.
- Use the Technical Support e-mail form at www.rabbit.com/support/questionSubmit.shtml.

If the sample programs ran fine, you are now ready to go on.

Additional sample programs are described in the *Dynamic C TCP/IP User's Manual*.

Refer to the *Dynamic C TCP/IP User's Manual* to develop your own applications. *An Introduction to TCP/IP* provides background information on TCP/IP, and is available on the [Web site](#).



APPENDIX A. SPECIFICATIONS

Appendix A provides the specifications for the BL2600 and describes the conformal coating.

Table A-1 lists the electrical, mechanical, and environmental specifications for the BL2600.

Table A-1. BL2600 Specifications

Feature	BL2600	BL2610
Microprocessor	Rabbit 3000® at 44.2 MHz	Rabbit 3000® at 29.4 MHz
Ethernet Port	10/100Base-T, 3 LEDs	None
Flash Memory	512K (standard)	
Program Execution SRAM	512K	—
Data SRAM	256K	512K
Backup Battery	Panasonic CR2477 or equivalent 3 V lithium coin type, 950 mA·h standard, socket-mounted	
Configurable I/O	16 individually software-configurable I/O channels may be configured as digital inputs ± 36 V DC, switching threshold 1.5 V typical, or as sinking digital outputs up to 40 V, 200 mA each	
Digital Inputs	8 inputs hardware-configurable pull-up or pull-down, ± 36 V DC, switching threshold 1.4 V typical	
High-Current Digital Outputs	4 outputs individually software-configurable as sinking or sourcing, +40 V DC, 2 A max. per channel	
Analog Inputs	Eight 11-bit res. channels, software-selectable ranges unipolar: 1, 2, 2.5, 5, 10, 20 V DC; bipolar ± 1 , ± 2 , ± 5 , ± 10 V DC; 4 channels can be hardware-configured for 4–20 mA; 1 M Ω input impedance, up to 4,100 samples/s	
Analog Outputs	Four 12-bit res. channels, buffered, 0–10 V DC, ± 10 VDC, and 4–20 mA, update rate 12 kHz	
Serial Ports	5 serial ports: <ul style="list-style-type: none"> • one RS-485 or one RS-232 • two RS-232 or one RS-232 (with CTS/RTS) • one clocked serial port multiplexed to two RS-422 SPI master ports • one serial port dedicated for programming/debug 	
Serial Rate	Max. asynchronous rate = CLK/8, Max. synchronous rate = CLK/2	
Connectors	<p>RJ-45 connectors: one Ethernet and two RabbitNet™</p> <p>Friction-lock connectors: two polarized 9-position terminals with 0.1" pitch three 4-position power terminals with 0.156" pitch two 20-position terminals with 0.1" pitch (2 \times 20 IDC option) one 13-position terminal with 0.1" pitch (2 \times 13 IDC option) one 10-position terminal with 0.1" pitch (2 \times 7 IDC option)</p> <p>Programming port: 2 \times 5 IDC, 1.27 mm pitch (BL2600), 2 \times 5 IDC, 2 mm pitch (BL2610)</p>	
Real-Time Clock	Yes	

Table A-1. BL2600 Specifications (continued)

Feature	BL2600	BL2610
Timers	Ten 8-bit timers (6 cascable, 3 reserved for internal peripherals), one 10-bit timer with 2 match registers	
Watchdog/Supervisor	Yes	
Power	9–36 V DC, 12 W max.	
Operating Temperature	–40°C to +70°C (–40°C to +85°C without battery)	
Humidity	5–95%, noncondensing	
Board Size	4.85" × 4.96" × 1.00" (123 mm × 126 mm × 25 mm)	

Other memory and clock speed options are available—see Section 1.2.2.

A.1.1 Exclusion Zone

It is recommended that you allow for an “exclusion zone” of 0.25" (6 mm) around the BL2600 in all directions when the BL2600 is incorporated into an assembly that includes other components. This “exclusion zone” that you keep free of other components and boards will allow for sufficient air flow, and will help to minimize any electrical or EMI interference between adjacent boards. An “exclusion zone” of 0.12" (3 mm) is recommended below the BL2600. Figure A-2 shows this “exclusion zone.”

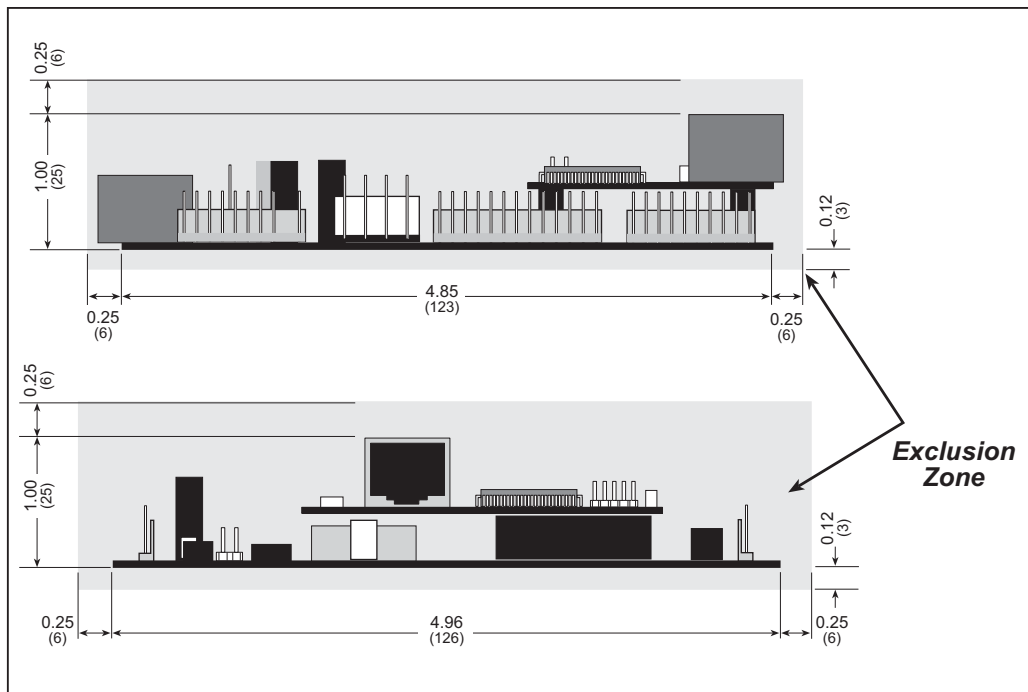

Figure A-2. BL2600 “Exclusion Zone”

A.1.2 Headers

The BL2600 has 0.1" IDC header sockets or friction-lock connectors at J1, J2, J3, J11, J13, J14, J15, J16, and J17 for physical connection to other boards or ribbon cables. There are friction-lock connectors at J5, J7, and J12 for power-supply connections, and at J8.

Figure A-3 shows the BL2600 footprint. These reference design values are relative to the mounting hole below the RabbitCore module.

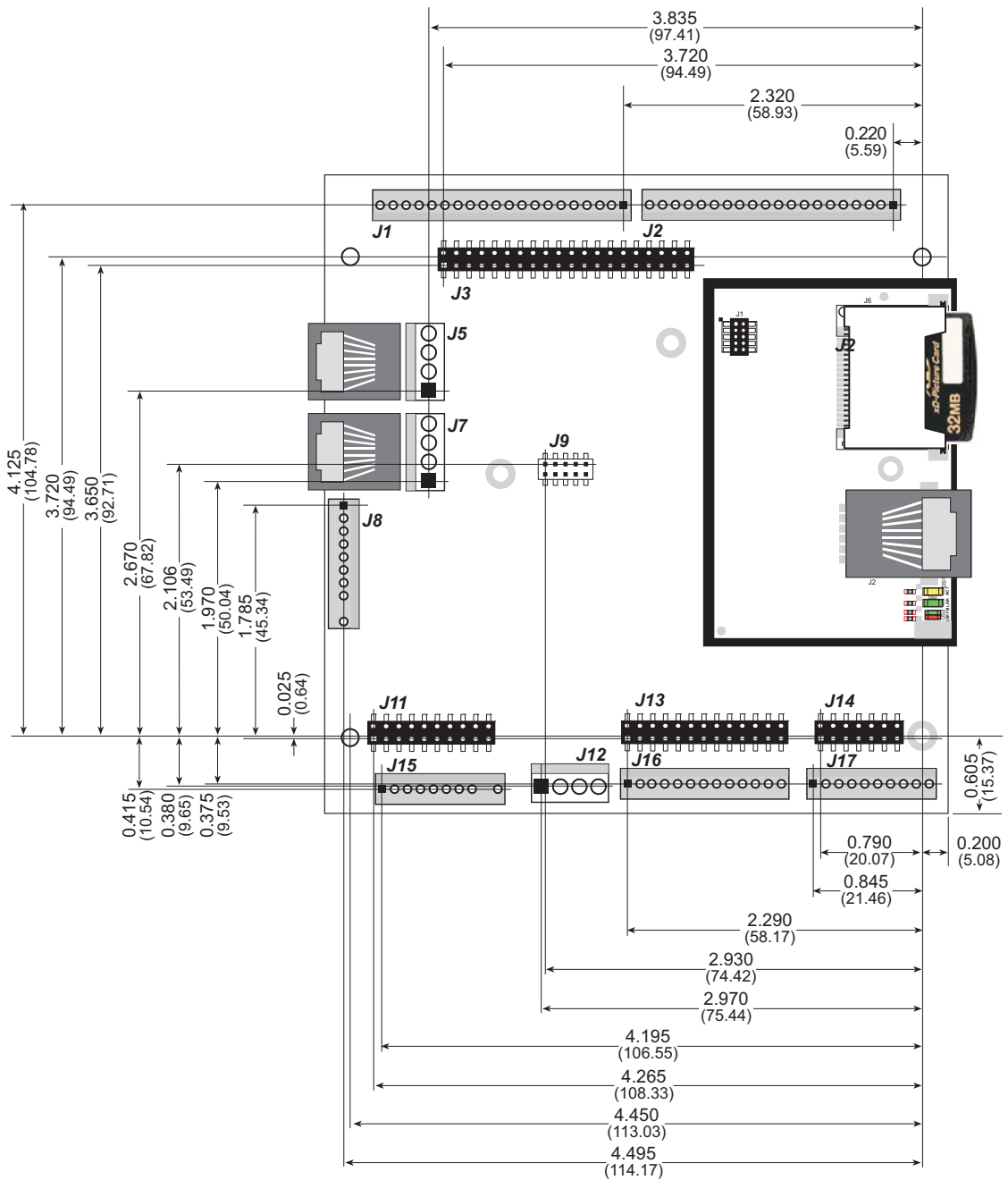

Figure A-3. User Board Footprint for BL2600

A.2 Conformal Coating

The areas around the crystal oscillator and the battery backup circuit on the BL2600 module have had the Dow Corning silicone-based 1-2620 conformal coating applied. The conformally coated areas are shown in Figure A-4. The conformal coating protects these high-impedance circuits from the effects of moisture and contaminants over time.

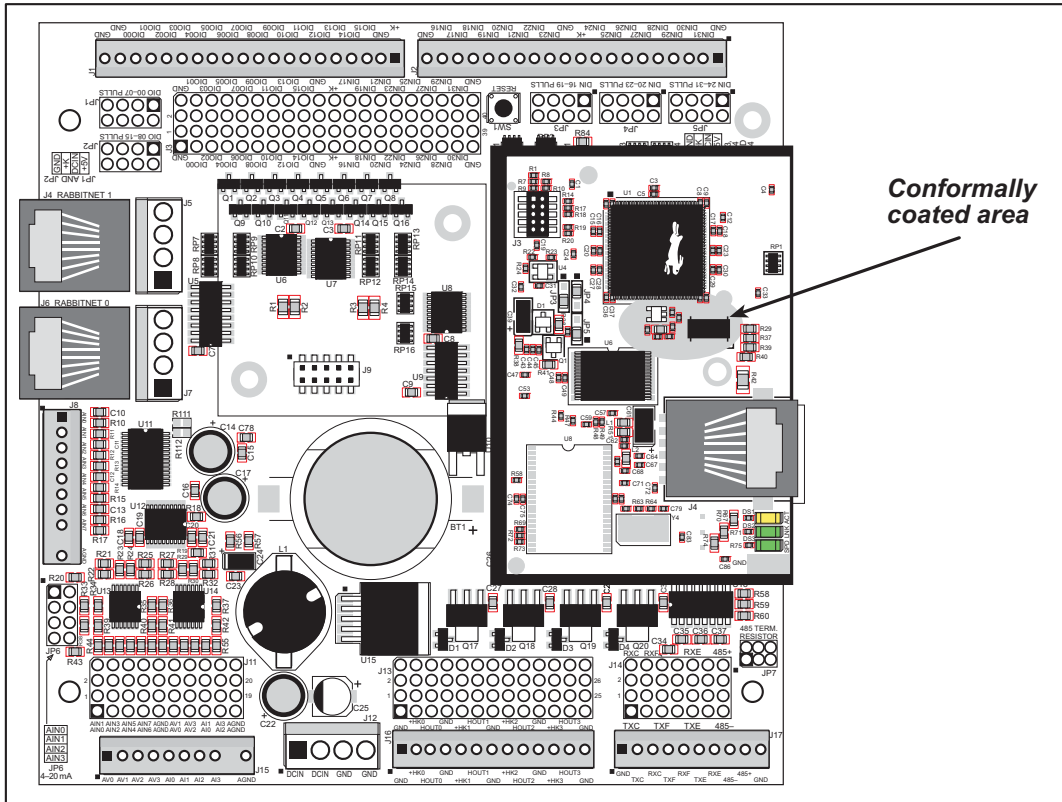

Figure A-4. BL2600 Areas Receiving Conformal Coating

Any components in the conformally coated area may be replaced using standard soldering procedures for surface-mounted components. A new conformal coating should then be applied to offer continuing protection against the effects of moisture and contaminants.

NOTE: For more information on conformal coatings, refer to Technical Note 303, *Conformal Coatings*.

A.3 Jumper Configurations

Figure A-5 shows the header locations used to configure the various BL2600 options via jumpers.

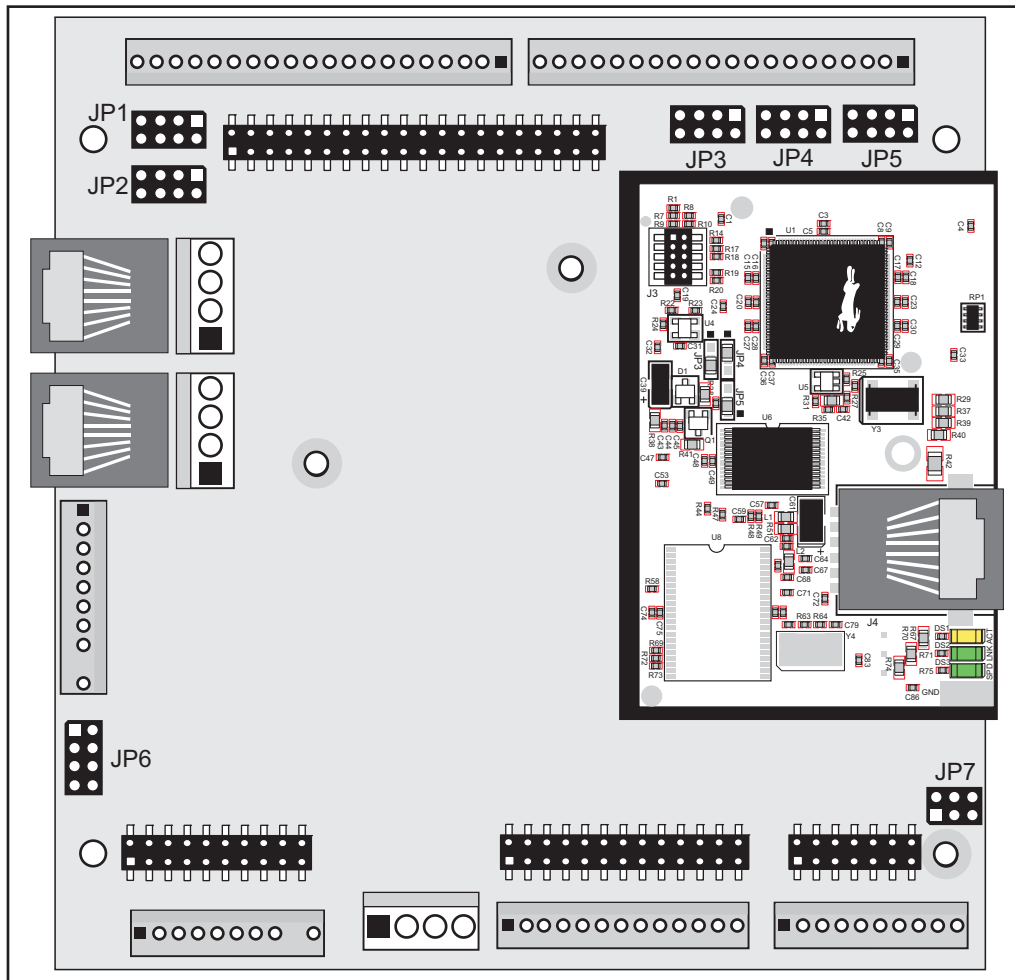

Figure A-5. Location of BL2600 Configurable Positions

Table A-2 lists the configuration options.

Table A-2. BL2600 Jumper Configurations

Header	Description	Pins Connected		Factory Default
JP1	DIO00–DIO07	1–2	Inputs pulled up to +5 V	✗
		3–4	Inputs pulled up to DCIN	
		5–6	Inputs pulled up to +K	
		7–8	Inputs pulled down to GND	

Table A-2. BL2600 Jumper Configurations

Header	Description	Pins Connected		Factory Default
JP2	DIO08–DIO15	1–2	Inputs pulled up to +5 V	✗
		3–4	Inputs pulled up to DCIN	
		5–6	Inputs pulled up to +K	
		7–8	Inputs pulled down to GND	
JP3	DIN16–DIN19	1–2	Inputs pulled up to +5 V	✗
		3–4	Inputs pulled up to DCIN	
		5–6	Inputs pulled up to +K	
		7–8	Inputs pulled down to GND	
JP4	DIN20–DIN23	1–2	Inputs pulled up to +5 V	✗
		3–4	Inputs pulled up to DCIN	
		5–6	Inputs pulled up to +K	
		7–8	Inputs pulled down to GND (needed for these to be PWM outputs)	
JP5	DIN24–DIN31	1–2	Inputs pulled up to +5 V	✗
		3–4	Inputs pulled up to DCIN	
		5–6	Inputs pulled up to +K	
		7–8	Inputs pulled down to GND	
JP6	A/D Converter Voltage/Current Measurement Options	None	Voltage Option	✗
		1–2	AIN0 4–20 mA option	
		3–4	AIN1 4–20 mA option	
		5–6	AIN2 4–20 mA option	
		7–8	AIN3 4–20 mA option	
JP7	RS-485 Bias and Termination Resistors	1–2 5–6	Bias and termination resistors connected	✗
		1–3 4–6	Bias and termination resistors <i>not</i> connected*	

* Although pins 1–3 and 4–6 of header JP7 are shown “jumpered” for the termination and bias resistors *not* connected, pins 3 and 4 are not actually connected to anything, and this configuration is a “parking” configuration for the jumpers so that they will be readily available should you need to enable the termination and bias resistors in the future.

A.4 Use of Rabbit 3000 Parallel Ports

Figure A-6 shows the Rabbit 3000 parallel ports.

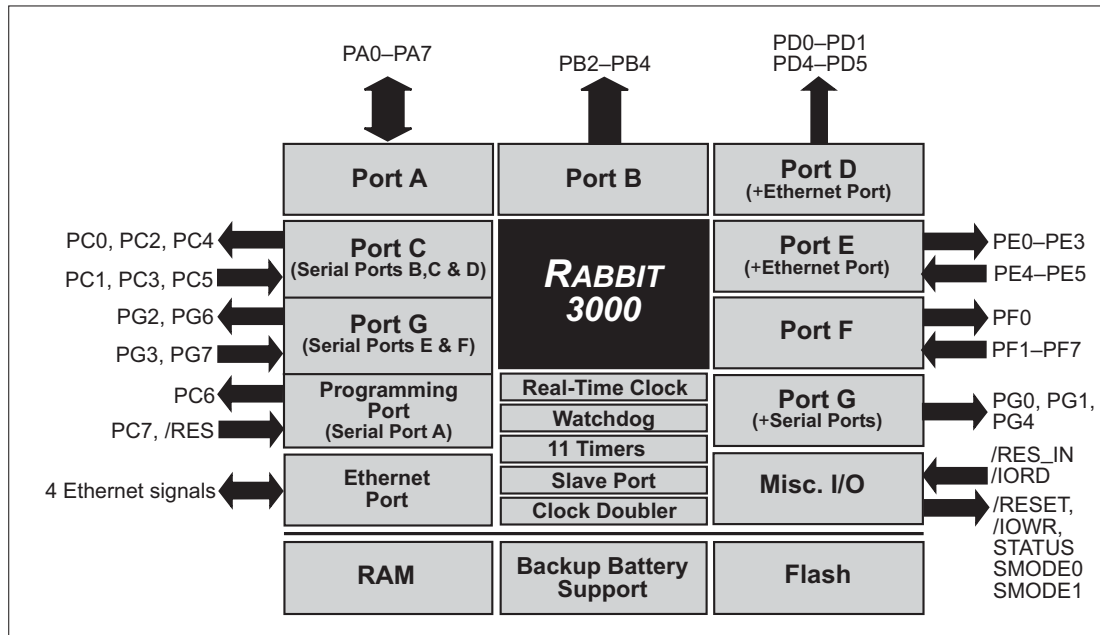

Figure A-6. BL2600 Rabbit-Based Subsystems

Table A-3 lists the Rabbit 3000 parallel ports and their use in the BL2600.

Table A-3. Use of Rabbit 3000 Parallel Ports

Port	I/O	Signal	Initial State
PA0-PA7	I/O	ID0-ID7	Pulled up
PB0-PB1	Input	Not connected	Pulled up
PB2-PB4	Output	IA0-IA2	High
PB5-PB7	Output	Not connected	High
PC0	Output	TXD SPI	Inactive high
PC1	Input	RXD SPI	Pulled up
PC2	Output	TXC RS-232	Inactive high
PC3	Input	RXC RS-232	Pulled up
PC4	Output	Not connected	Inactive high
PC5	Input	Not connected	Pulled up
PC6	Output	TXA Programming Port	Low
PC7	Input	RXA Programming Port	Pulled up

Table A-3. Use of Rabbit 3000 Parallel Ports (continued)

Port	I/O	Signal	Initial State
PD0–PD1	Output/ENET	Not connected or Ethernet	See Note
PD2–PD3	Output	Not connected	Low
PD4	Output	Load D/A converter data	Low
PD5	Output	RS-485/RS-232 select	Low
PD6–PD7	Output	Not connected	Low
PE0	Output/ENET	Not connected or Ethernet	See Note
PE1	Output	/CS strobe (digital I/O enable)	Inactive high
PE2	Output/ENET	Not connected or Ethernet	See Note
PE3	Output	RS-485 transmit control	Low
PE4–PE5	Input	IN00–IN01	Pulled up
PE6–PE7	Output	Not connected	Low
PF0	Output	Serial CLKD	Low
PF1	Input	A/D converter busy	Pulled up
PF2–PF7	Input	IN02–IN07	Pulled up
PG0	Output	EEPROM CLK	—
PG1	Output	EEPROM data	Pulled up
PG2	Output	TXF RS-232	Serial Port F
PG3	Input	RXF RS-232	
PG4	Output	/CS (digital output enable)	Low
PG5	Output	Not connected	Low
PG6	Output	TXE RS-232	Serial Port E
PG7	Input	RXE RS-232	

The PD0, PD1, PE0, and PE2 signals are configured on the RabbitCore module, and not on the BL2600. These parallel-port bits are configured for Ethernet on RabbitCore modules with Ethernet and for output low on RabbitCore modules without Ethernet. The signals are not available on the BL2600 for customer use in applications.

APPENDIX B. POWER SUPPLY

Appendix B describes the power circuitry provided on the BL2600.

B.1 Power Supplies

Power is supplied to the BL2600 via the friction-lock connector at J12. The BL2600 is protected against reverse polarity by a diode at D1 as shown in Figure B-1.

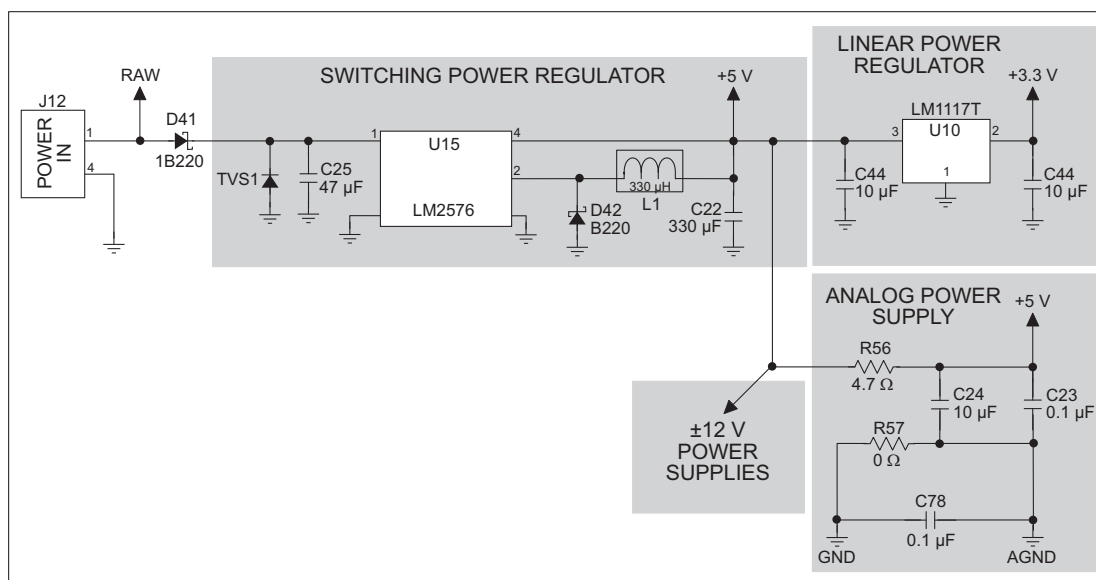

Figure B-1. BL2600 Power Supply

The input voltage range is from 9 V to 36 V. A switching power regulator is used to provide +5 V for the BL2600 logic circuits. In turn, the regulated +5 V DC power supply is used to drive a regulated +3.3 V power supply and ±12 V power supplies used by the op-amps driving the digital outputs.

The digital ground and the analog ground share a single split ground plane on the board, with the analog ground connected at a single point to the digital ground by a 0 Ω resistor (R57). This is done to minimize digital noise in the analog circuits and to eliminate the possibility of ground loops. External connections to analog ground are made on a polarized friction-lock connector at J8.

B.1.1 Power for Analog Circuits

Power to the analog circuits is provided by way of a one-stage low-pass filter, which isolates the analog section from digital noise generated by the other components. The analog +5 V supply powers the D/A converter, and is not accessible to the user. The A/D converter is powered by the regulated +3.3 V supply, and supplies the +2.048 V reference voltages from which the 1.667 V and 2.5 V reference voltages for the D/A converter output circuits are derived.

B.2 Batteries and External Battery Connections

The SRAM and the real-time clock on the BL2600 module have battery backup. Power to the SRAM and the real-time clock (VRAM) is provided by two different sources, depending on whether the main part of the BL2600 is powered or not. When the BL2600 is powered normally, and the +3.3 V supply is within operating limits, the SRAM and the real-time clock are powered from the +3.3 V supply. If power to the board is lost or falls below 2.93 V (2.63 V on the BL2610), the VRAM and real-time clock power will come from the battery. The reset generator circuit controls the source of power by way of its **/RESET** output signal.

A replaceable 950 mA·h lithium battery provides power to the real-time clock and SRAM when external power is removed from the circuit board. The drain on the battery is typically less than 10 μ A when there is no external power applied to the BL2600, and so the expected shelf life of the battery is

$$\frac{950 \text{ mA}\cdot\text{h}}{12 \text{ }\mu\text{A}} = 9.0 \text{ years.}$$

B.2.1 Replacing the Backup Battery

The battery is user-replaceable, and is fitted in a battery holder. To replace the battery, lift up on the spring clip and slide out the old battery. Use only a Panasonic CR2477 or equivalent replacement battery, and insert it into the battery holder with the + side facing up.

NOTE: The SRAM contents and the real-time clock settings will be lost if the battery is replaced with no power applied to the BL2600. Exercise care if you replace the battery while external power is applied to the BL2600.



CAUTION: There is an explosion danger if the battery is short-circuited, recharged, or replaced incorrectly. Replace the battery only with the same type or an equivalent type recommended by the battery manufacturer. Dispose of used batteries according to the battery manufacturer's instructions.

Cycle the main power off/on on the BL2600 whenever you replace the backup battery. This step will minimize the current drawn by the real-time clock oscillator circuit from the backup battery should the BL2600 experience a loss of main power.

NOTE: Remember to cycle the main power off/on any time the BL2600's RabbitCore module is removed from the main board since removing the RabbitCore module disconnects power to its real-time clock oscillator.

B.3 Power to Peripheral Boards

DCIN and Vcc are available on friction-lock connector terminals J5 and J7 to power peripheral boards that may be used with the BL2600.

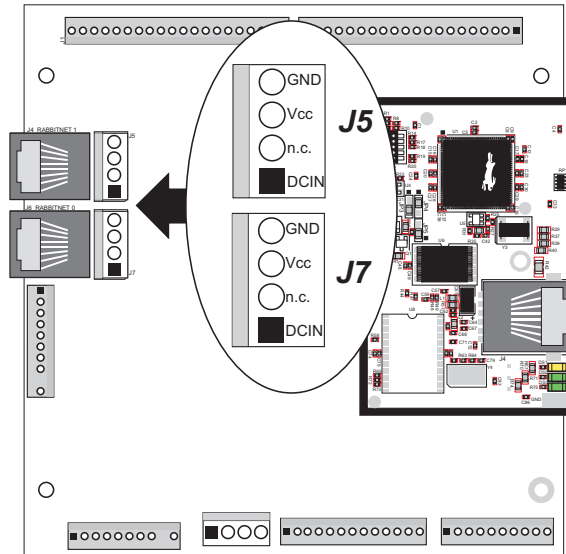

Figure B-2. Pinout Friction-Lock Connector Terminals J5 and J7

Keep in mind that the BL2600 draws 377 mA from the Vcc supply, and that the diode at D41 (shown in Figure B-1) can handle at most 1 A at V_{RAW} , so that leaves the remaining current capacity to be shared among the DCIN and Vcc pins on friction-lock connector terminals J5 and J7. Table B-1 lists the available current at DCIN based on the current drawn at Vcc.

**Table B-1. DCIN Current Available at J7 and J8 (in mA)
Based on Power Supply and Vcc (= 5 V) Current Used at J5 and J7**

V_{RAW} Power Supply Input at J2 (V)	Current at J5 and J7 with Vcc = 5 V						
	100 mA	200 mA	300 mA	400 mA	500 mA	600 mA	623 mA
8.0	545	450	355	260	164	69	47
8.5	574	484	395	306	216	127	107
9.0	599	515	431	347	263	178	159
10	641	566	490	415	340	265	248
12	703	641	579	517	455	393	378
18	805	764	723	682	642	601	591
24	855	824	794	763	733	703	696
30	884	860	836	811	787	763	750
40	913	895	877	859	841	823	819



APPENDIX C. DEMONSTRATION BOARD

Appendix C shows how to connect the Demonstration Board to the BL2600.

C.1 Connecting Demonstration Board

Before running sample programs based on the Demonstration Board, you will have to connect the Demonstration Board from the BL2600 Tool Kit to the BL2600 board. Proceed as follows.

1. Use the wires included in the BL2600 Tool Kit to connect header J1 on the Demonstration Board to screw-terminal headers J1 and J12 on the BL2600. The connections are shown in Figure C-1 for sample program **DIGIN.C** and for sample program **SMTP.C**, in Figure C-2 for sample program **DIGOUT.C** and for sample program **SSI.C**, and in Figure C-3 for sample program **HIGH_CURRENT_IO.C**.
2. Make sure that your BL2600 is connected to your PC via the programming cable and that the power supply is connected to the BL2600 and plugged in as described in Chapter 2, “Getting Started.”

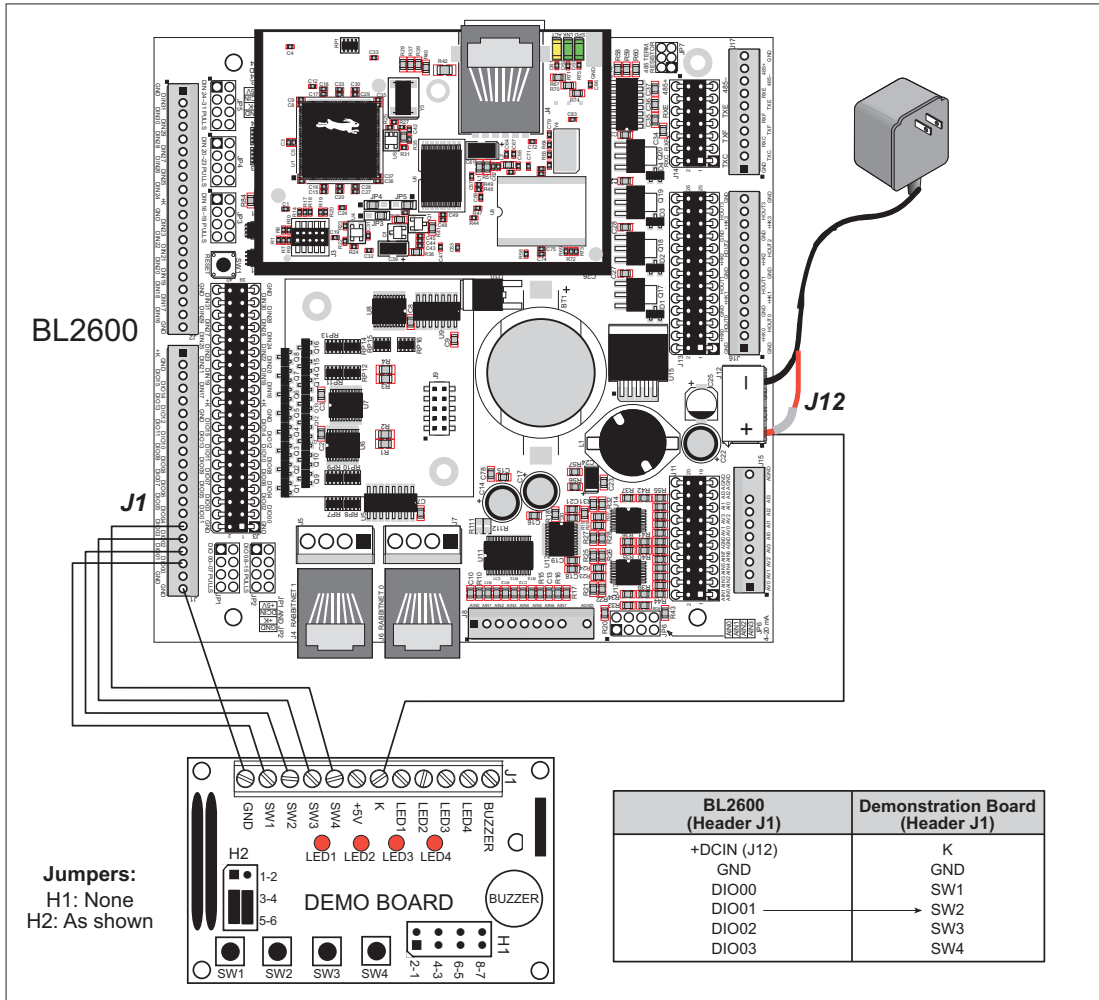

Figure C-1. General Digital Input Connections Between BL2600 and Demonstration Board

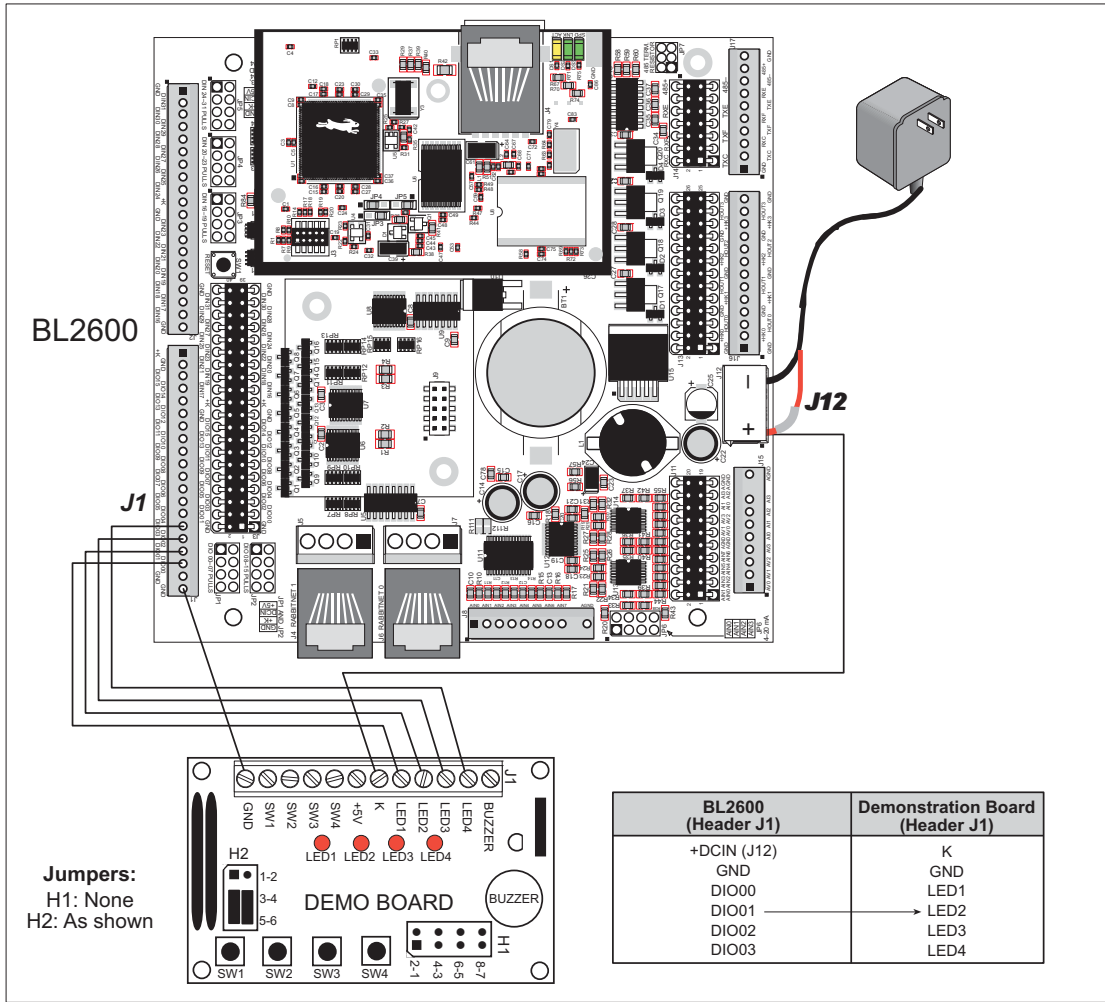

Figure C-2. Digital Output Connections Between BL2600 and Demonstration Board

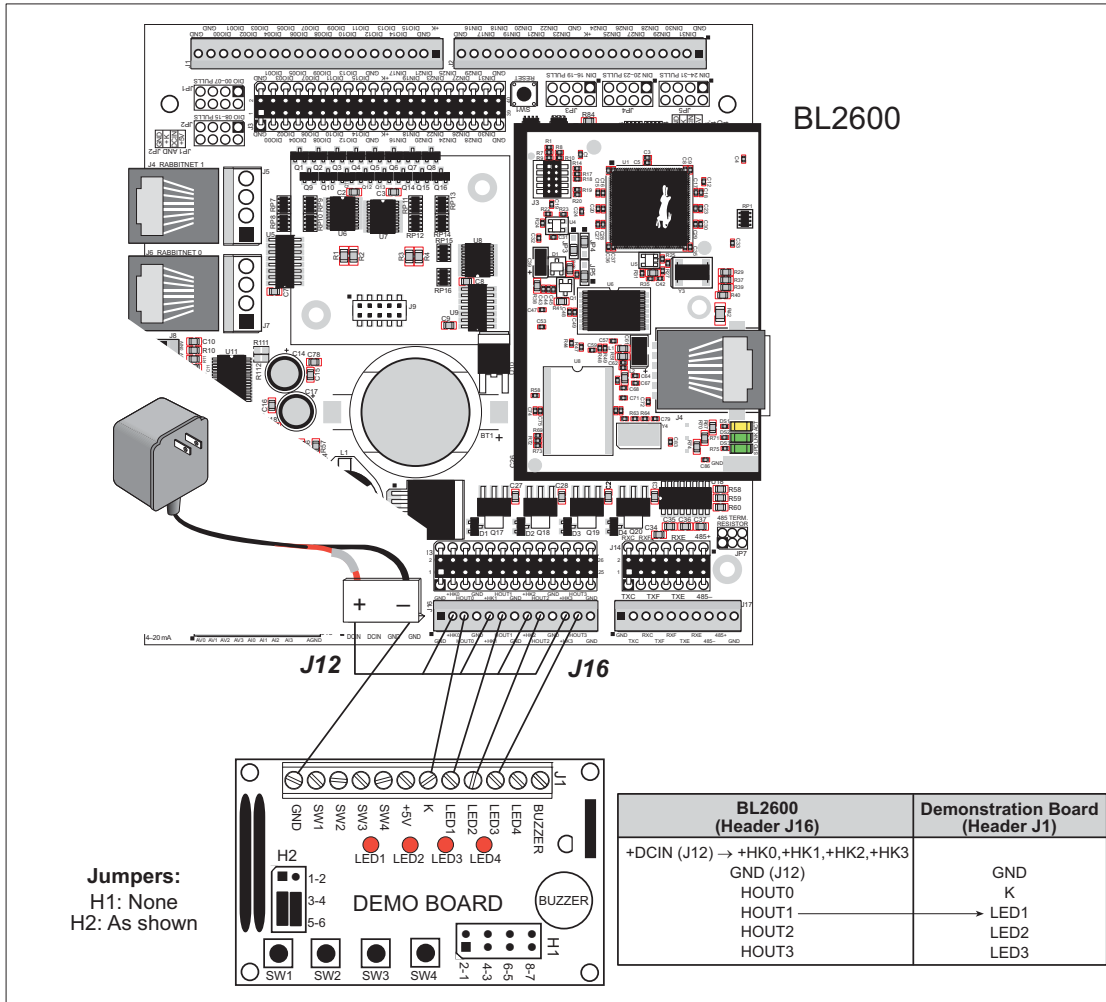

Figure C-3. HIGH_CURRENT_IO.C Connections Between BL2600 and Demonstration Board

NOTE: +HK0...+HK3 on header J16 must be connected to +DCIN on friction-lock connector J12 as shown in Figure C-3.

APPENDIX D. RABBITNET

D.1 General RabbitNet Description

RabbitNet is a high-speed synchronous protocol developed by Rabbit to connect peripheral cards to a master and to allow them to communicate with each other.

D.1.1 RabbitNet Connections

All RabbitNet connections are made point to point. A RabbitNet master port can only be connected directly to a peripheral card, and the number of peripheral cards is limited by the number of available RabbitNet ports on the master.

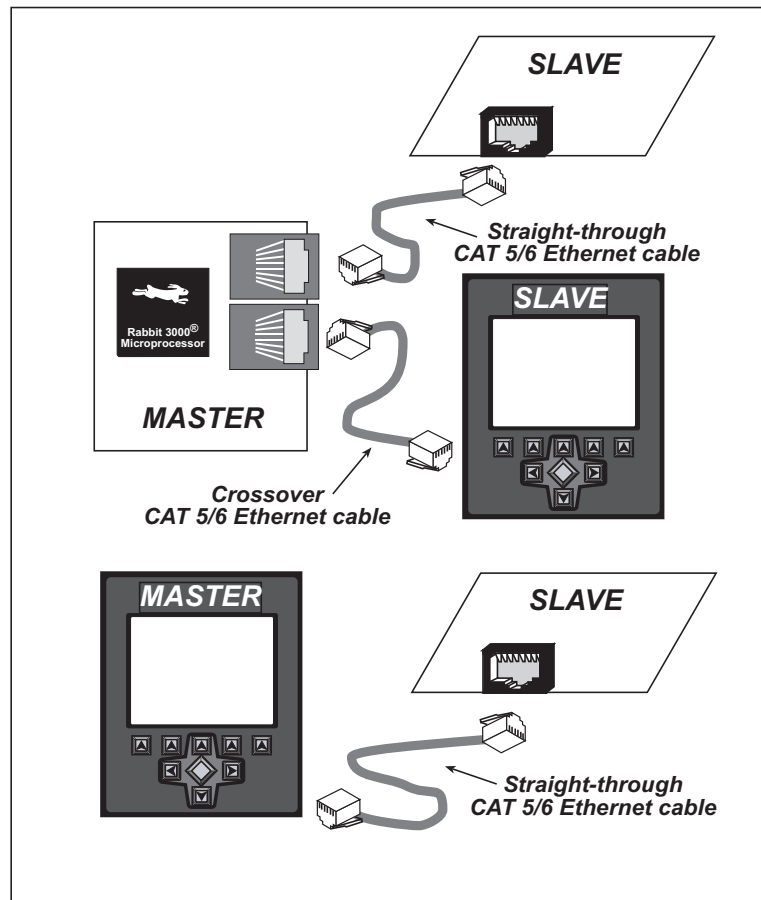

Figure D-1. Connecting Peripheral Cards to a Master

Use a straight-through CAT 5/6 Ethernet cable to connect the master to slave peripheral cards, unless you are using a device such as the OP7200 that could be used either as a master or a slave. In this case you would use a crossover CAT 5/6 Ethernet cable to connect an OP7200 that is being used as a slave.

Distances between a master unit and peripheral cards can be up to 10 m or 33 ft.

D.1.2 RabbitNet Peripheral Cards

- Digital I/O

24 inputs, 16 push/pull outputs, 4 channels of 10-bit A/D conversion with ranges of 0 to 10 V, 0 to 1 V, and -0.25 to +0.25 V. The following connectors are used:

Signal = 0.1" friction-lock connectors

Power = 0.156" friction-lock connectors

RabbitNet = RJ-45 connector

- A/D converter

8 channels of programmable-gain 12-bit A/D conversion, configurable as current measurement and differential-input pairs. 2.5 V reference voltage is available on the connector. The following connectors are used:

Signal = 0.1" friction-lock connectors

Power = 0.156" friction-lock connectors

RabbitNet = RJ-45 connector

- D/A converter

8 channels of 0–10 V 12-bit D/A conversion. The following connectors are used:

Signal = 0.1" friction-lock connectors

Power = 0.156" friction-lock connectors

RabbitNet = RJ-45 connector

- Display/Keypad interface

Allows you to connect your own keypad with up to 64 keys and one character liquid crystal display from 1 × 8 to 4 × 40 characters with or without backlight using standard 1 × 16 or 2 × 8 connectors. The following connectors are used:

Signal = 0.1" headers or sockets

Power = 0.156" friction-lock connectors

RabbitNet = RJ-45 connector

- Relay card

6 relays rated at 250 V AC, 1200 V·A or 100 V DC up to 240 W. The following connectors are used:

Relay contacts = screw-terminal connectors

Power = 0.156" friction-lock connectors

RabbitNet = RJ-45 connector

Visit our [Web site](#) for up-to-date information about additional cards and features as they become available. The Web site also has the latest revision of this user's manual.

D.2 Physical Implementation

There are four signaling functions associated with a RabbitNet connection. From the master's point of view, the transmit function carries information and commands to the peripheral card. The receive function is used to read back information sent to the master by the peripheral card. A clock is used to synchronize data going between the two devices at high speed. The master is the source of this clock. A slave select (SS) function originates at the master, and when detected by a peripheral card causes it to become selected and respond to commands received from the master.

The signals themselves are differential RS-422, which are series-terminated at the source. With this type of termination, the maximum frequency is limited by the round-trip delay time of the cable. Although a peripheral card could theoretically be up to 45 m (150 ft) from the master for a data rate of 1 MHz, Rabbit recommends a practical limit of 10 m (33 ft).

Connections between peripheral cards and masters are done using standard 8-conductor CAT 5/6 Ethernet cables. Masters and peripheral cards are equipped with RJ-45 8-pin female connectors. The cables may be swapped end for end without affecting functionality.

D.2.1 Control and Routing

Control starts at the master when the master asserts the slave select signal (SS). Then it simultaneously sends a serial command and clock. The first byte of a command contains the address of the peripheral card if more than one peripheral card is connected.

A peripheral card assumes it is selected as soon as it receives the select signal. For direct master-to-peripheral-card connections, this is as soon as the master asserts the select signal. The connection is established once the select signal reaches the addressed slave. At this point communication between the master and the selected peripheral card is established, and data can flow in both directions simultaneously. The connection is maintained so long as the master asserts the select signal.

D.3 Function Calls

The function calls described in this section are used with all RabbitNet peripheral cards, and are available in the `RNET.LIB` library in the Dynamic C `RABBITNET` folder.

```
int rn_init(char portflag, char servicetype);
```

Resets, initializes, or disables a specified RabbitNet port on the master single-board computer. During initialization, the network is enumerated and relevant tables are filled in. If the port is already initialized, calling this function forces a re-enumeration of all devices on that port.

Call this function first before using other RabbitNet functions.

PARAMETERS

portflag is a bit that represents a RabbitNet port on the master single-board computer (from 0 to the maximum number of ports). A set bit requires a service. If **portflag** = 0x03, both RabbitNet ports 0 and 1 will need to be serviced.

servicetype enables or disables each RabbitNet port as set by the port flags.

0 = disable port

1 = enable port

RETURN VALUE

0

```
int rn_device(char pna);
```

Returns an address index to device information from a given physical node address. This function will check device information to determine that the peripheral card is connected to a master.

PARAMETER

pna is the physical node address, indicated as a byte.

7,6—2-bit binary representation of the port number on the master

5,4,3—Level 1 router downstream port

2,1,0—Level 2 router downstream port

RETURN VALUE

Pointer to device information. -1 indicates that the peripheral card either cannot be identified or is not connected to the master.

SEE ALSO

`rn_find`

```
int rn_find(rn_search *srch);
```

Locates the first active device that matches the search criteria.

PARAMETER

srch is the search criteria structure **rn_search**:

```
    unsigned int flags;    // status flags see MATCH macros below
    unsigned int ports;    // port bitmask
    char productid;       // product id
    char productrev;      // product rev
    char coderev;         // code rev
    long serialnum;       // serial number
```

Use a maximum of 3 macros for the search criteria:

```
    RN_MATCH_PORT        // match port bitmask
    RN_MATCH_PNA         // match physical node address
    RN_MATCH_HANDLE      // match instance (reg 3)
    RN_MATCH_PRDID       // match id/version (reg 1)
    RN_MATCH_PRDREV      // match product revision
    RN_MATCH_CODEREV     // match code revision
    RN_MATCH_SN          // match serial number
```

For example:

```
rn_search newdev;
newdev.flags = RN_MATCH_PORT|RN_MATCH_SN;
newdev.ports = 0x03; //search ports 0 and 1
newdev.serialnum = E3446C01L;
handle = rn_find(&newdev);
```

RETURN VALUE

Returns the handle of the first device matching the criteria. 0 indicates no such devices were found.

SEE ALSO

`rn_device`

```
int rn_echo(int handle, char sendecho,
            char *recdata);
```

The peripheral card sends back the character the master sent. This function will check device information to determine that the peripheral card is connected to a master.

PARAMETERS

handle is an address index to device information. Use `rn_device()` or `rn_find()` to establish the handle.

sendecho is the character to echo back.

recdata is a pointer to the return address of the character from the device.

RETURN VALUE

The status byte from the previous command. -1 means that device information indicates the peripheral card is not connected to the master.

```
int rn_write(int handle, int regno, char *data,  
int datalen);
```

Writes a string to the specified device and register. Waits for results. This function will check device information to determine that the peripheral card is connected to a master.

PARAMETERS

handle is an address index to device information. Use `rn_device()` or `rn_find()` to establish the handle.

regno is the command register number as designated by each device.

data is a pointer to the address of the string to write to the device.

datalen is the number of bytes to write (0–15).

NOTE: A data length of 0 will transmit the one-byte command register number.

RETURN VALUE

The status byte from the previous command. -1 means that device information indicates the peripheral card is not connected to the master, and -2 means that the data length was greater than 15.

SEE ALSO

`rn_read`

```
int rn_read(int handle, int regno, char *reodata,  
int datalen);
```

Reads a string from the specified device and register. Waits for results. This function will check device information to determine that the peripheral card is connected to a master.

PARAMETERS

handle is an address index to device information. Use `rn_device()` or `rn_find()` to establish the handle.

regno is the command register number as designated by each device.

reodata is a pointer to the address of the string to read from the device.

datalen is the number of bytes to read (0–15).

NOTE: A data length of 0 will transmit the one-byte command register number.

RETURN VALUE

The status byte from the previous command. -1 means that device information indicates the peripheral card is not connected to the master, and -2 means that the data length was greater than 15.

SEE ALSO

`rn_write`

```
int rn_reset(int handle, int resettype);
```

Sends a reset sequence to the specified peripheral card. The reset takes approximately 25 ms before the peripheral card will once again execute the application. Allow 1.5 seconds after the reset has completed before accessing the peripheral card. This function will check peripheral card information to determine that the peripheral card is connected to a master.

PARAMETERS

handle is an address index to device information. Use `rn_device()` or `rn_find()` to establish the handle.

resettype describes the type of reset.

0 = hard reset—equivalent to power-up. All logic is reset.

1 = soft reset—only the microprocessor logic is reset.

RETURN VALUE

The status byte from the previous command. -1 means that device information indicates the peripheral card is not connected to the master.

```
int rn_sw_wdt(int handle, float timeout);
```

Sets software watchdog timeout period. Call this function prior to enabling the software watchdog timer. This function will check device information to determine that the peripheral card is connected to a master.

PARAMETERS

handle is an address index to device information. Use `rn_device()` or `rn_find()` to establish the handle.

timeout is a timeout period from 0.025 to 6.375 seconds in increments of 0.025 seconds. Entering a zero value will disable the software watchdog timer.

RETURN VALUE

The status byte from the previous command. -1 means that device information indicates the peripheral card is not connected to the master.

```
int rn_enable_wdt(int handle, int wdtttype);
```

Enables the hardware and/or software watchdog timers on a peripheral card. The software on the peripheral card will keep the hardware watchdog timer updated, but will hard reset if the time expires. The hardware watchdog cannot be disabled except by a hard reset on the peripheral card. The software watchdog timer must be updated by software on the master. The peripheral card will soft reset if the timeout set by `rn_sw_wdt()` expires. This function will check device information to determine that the peripheral card is connected to a master.

PARAMETERS

handle is an address index to device information. Use `rn_device()` or `rn_find()` to establish the handle.

wdtttype

0 enables both hardware and software watchdog timers

1 enables hardware watchdog timer

2 enables software watchdog timer

RETURN VALUE

The status byte from the previous command. -1 means that device information indicates the peripheral card is not connected to the master.

SEE ALSO

`rn_hitwd`, `rn_sw_wdt`

```
int rn_hitwd(int handle, char *count);
```

Hits software watchdog. Set the timeout period and enable the software watchdog prior to using this function. This function will check device information to determine that the peripheral card is connected to a master.

PARAMETERS

handle is an address index to device information. Use `rn_device()` or `rn_find()` to establish the handle.

count is a pointer to return the present count of the software watchdog timer. The equivalent time left in seconds can be determined from `count × 0.025` seconds.

RETURN VALUE

The status byte from the previous command. -1 means that device information indicates the peripheral card is not connected to the master.

SEE ALSO

`rn_enable_wdt`, `rn_sw_wdt`

```
int rn_rst_status(int handle, char *retdata);
```

Reads the status of which reset occurred and whether any watchdogs are enabled.

PARAMETERS

handle is an address index to device information. Use **rn_device()** or **rn_find()** to establish the handle.

retdata is a pointer to the return address of the communication byte. A set bit indicates which error occurred. This register is cleared when read.

- 7—HW reset has occurred
- 6—SW reset has occurred
- 5—HW watchdog enabled
- 4—SW watchdog enabled
- 3,2,1,0—Reserved

RETURN VALUE

The status byte from the previous command.

```
int rn_comm_status(int handle, char *retdata);
```

PARAMETERS

handle is an address index to device information. Use **rn_device()** or **rn_find()** to establish the handle.

retdata is a pointer to the return address of the communication byte. A set bit indicates which error occurred. This register is cleared when read.

- 7—Data available and waiting to be processed MOSI (master out, slave in)
- 6—Write collision MISO (master in, slave out)
- 5—Overrun MOSI (master out, slave in)
- 4—Mode fault, device detected hardware fault
- 3—Data compare error detected by device
- 2,1,0—Reserved

RETURN VALUE

The status byte from the previous command.

D.3.1 Status Byte

Unless otherwise specified, functions returning a status byte will have the following format for each designated bit.

7	6	5	4	3	2	1	0	
×	×							00 = Reserved 01 = Ready 10 = Busy 11 = Device not connected
		×						0 = Device 1 = Router
			×					0 = No error 1 = Communication error*
				×				Reserved for individual peripheral cards
					×			Reserved for individual peripheral cards
						×		0 = Last command accepted 1 = Last command unexecuted
							×	0 = Not expired 1 = HW or SW watchdog timer expired†

* Use the function `rn_comm_status()` to determine which error occurred.

† Use the function `rn_rst_status()` to determine which timer expired.



SCHEMATICS

090-0195 BL2600 Schematic

www.rabbit.com/documentation/schemat/090-0195.pdf

090-0214 RCM3365/RCM3375 Module Schematic

www.rabbit.com/documentation/schemat/090-0214.pdf

090-0120 RCM3200 Module Schematic

www.rabbit.com/documentation/schemat/090-0152.pdf

090-0119 RCM3100 Module Schematic

www.rabbit.com/documentation/schemat/090-0144.pdf

090-0042 Demonstration Board Schematic

www.rabbit.com/documentation/schemat/090-0042.pdf

090-0128 Programming Cable Schematic

www.rabbit.com/documentation/schemat/090-0128.pdf

You may use the URL information provided above to access the latest schematics directly.

INDEX

A

A/D converter 29
buffered inputs 29
calibration 30
calibration constants 30
current-measurement setup 30
function calls
 anaIn 62
 anaInCalib 60
 anaInVolts 63, 64, 65
analog I/O
 reference voltage circuit 33
 reference voltages 33
analog inputs *See* A/D converter
analog outputs *See* D/A converter

B

battery backup
 use of battery-backed SRAM
 70
battery connections 88
board initialization
 function calls 48
 brdInit 48

C

CE compliance 6
 design guidelines 7
clock doubler 35
conformal coating 82
connections
 Ethernet cable 71
connectivity tools
 crimp tool 5
 friction-lock connector parts .
 18
 RS-232/USB converter 5
connector options 3

D

D/A converter 31

calibration 32
calibration constants 32
function calls
 anaOut 68
 anaOutCalib 67
 anaOutVolts 68
Demonstration Board 4
 hookup instructions 91
 digital input sample programs 92
 digital output sample programs 93
 TCP/IP sample programs ..
 92, 94
 jumper configurations 92, 93,
 94
 wire assembly 4
digital I/O
 function calls
 digIn 56
 digOut 50
 digOutConfig 21
digital inputs 19
 pullup/pulldown configuration
 19
 switching threshold 20, 24
digital outputs 21
 sinking or sourcing 21
dimensions
 BL2600 main board 78
Dynamic C 5, 39, 40
 add-on modules 12, 41
 installation 12
 basic instructions 39
 battery-backed SRAM 70
 debugging features 40
 installation 12
 protected variables 70
 standard features
 debugging 40
 starting 13
 telephone-based technical support 5, 41
 upgrades and patches 41

E

Ethernet cables 71
Ethernet connections 71
 steps 71
Ethernet port 28
 pinout 28
exclusion zone 80

F

features 1
flash memory
 lifetime write cycles 39
 serial flash 36
flash memory addresses
 user blocks 36
friction-lock connectors
 parts 18

H

headers
 BL2600
 JP1 24
 JP2 24
 JP3 19
 JP4 19
 JP5 19
 JP6 30
 JP7 26
 Demonstration Board
 H1 92, 93, 94
 H2 92, 93, 94

I

IP addresses 74
 how to set 73
 how to set PC IP address .. 74

J

jumper configurations 83
 Demonstration Board . 92, 93,
 94
 JP1 (digital input DIO00–

DIO07 pullup/pulldown configuration)	24, 83	Ethernet port	28	RS-485	25
JP2 (digital input DIO08–DIO15 pullup/pulldown configuration)	24, 84	power management	87	RS-485 network	26
JP3 (digital input DIN16–DIN19 pullup/pulldown configuration)	19, 84	power supply	87	termination and bias resistors	26
JP4 (digital input DIN20–DIN23 pullup/pulldown configuration)	19, 20, 84	battery backup	88	Run Mode	34
JP5 (digital input DIN24–DIN31 pullup/pulldown configuration)	19, 84	connections	10	S	
JP6 (A/D converter voltage/current measurement options)	30, 84	RabbitNet peripheral boards	89	sample programs	42
JP7 (RS-485 bias and termination resistors)	26, 84	switching voltage regulator	87	A/D converter	
jumper locations	83	Program Mode	34	AD_CAL_ALL.C	30
module flash memory bank select	36	programming		AD_CALDIFF_CH.C	30
M		flash vs. RAM	39	AD_RD_DIFF.C	44
memory	36	programming cable	4	AD_RD_MA.C	44
flash memory configurations	36	programming port	27	AD_RD_SE_BIPOLAR.C	45
insertion/removal of memory card	37	programming cable	4	AD_RD_SE_UNIPO-LAR.C	45
NAND flash options	37	connections	10	AD_RDVOLT_ALL.C	30
SRAM configuration for different sizes	36	PROG connector	34	ADC_CAL_DIFF.C	44
models	2	switching between Program Mode and Run Mode	34	ADC_CAL_MA.C	32, 44
additional Ethernet options	3	PWM outputs	20	ADC_CAL_SE_BIPO-LAR.C	44
additional memory options	3	jumper configuration	20	ADC_CAL_SE_UNIPO-LAR.C	44
BL2600	2	R		ADC_RD_CALDATA.C	44
BL2610	2	Rabbit 3000		ADC_RD_CALDATA.C	44
connector options	3	parallel ports	85	BOARD_ID.C	42
memory, clock speed, and Ethernet options	3	RabbitNet		D/A converter	
O		Ethernet cables to connect peripheral boards	95, 96	DAC_CAL_MA.C	45
options		function calls		DAC_CAL_VOLTS.C	45
connectors	3	rn_comm_status	103	DAC_MA_ASYNC.C	45
P		rn_device	98	DAC_MA_SYNC.C	45
peripheral boards		rn_echo	99	DAC_RD_CALDATA.C	45
connection to master	95, 96	rn_enable_wdt	102	DAC_VOLT_ASYNC.C	45
power from BL2500	89	rn_find	99	DAC_VOLT_SYNC.C	46
RabbitNet power-supply connections	89	rn_hitwd	102	digital I/O	
pinout		rn_init	98	DIGIN_BANK.C	42
BL2600 headers	16	rn_read	100	DIGIN.C	42
		rn_reset	101	DIGOUT_BANK.C	42
		rn_rst_status	103	DIGOUT.C	42
		rn_sw_wdt	101	HIGH_CURRENT_IO.C	43
		rn_write	100	PWM.C	43
		general description	95	how to set IP address	73
		peripheral boards	96	NAND flash	
		A/D converter	96	NFLASH_DUMP.C	46
		D/A converter	96	NFLASH_ERASE.C	47
		digital I/O	96	NFLASH_INSPECT.C	46
		display/keypad interface	96	NFLASH_LOG.C	46
		relay card	96	PONG.C	14
		physical implementation	97	real-time clock	
		real-time clock		RTC_TEST.C	47
		how to set	47		
		reset			
		hardware	11		
		RS-232	25		

SETRTCKB.C	47	temperature	79
serial communication		dimensions (BL2600 main	
MASTER.C	44	board)	78
PUTS.C	43	spectrum spreader	
SIMPLE3WIRE.C	43	settings	35
SIMPLE5WIRE.C	43	status byte	104
SLAVE.C	44	subsystems	15
SF1000 serial flash card		T	
FLASH_PATTERN_IN-		TCP/IP connections	71
SPECT.C	46	10Base-T Ethernet card	71
SFLASH_TEST.C	46	additional resources	76
TCP/IP	47, 73	Ethernet hub	71
PINGME.C	75	steps	71
SMTP.C	76	Tool Kit	4
SSIC	76	AC adapter	4
TELNET.C	76	DC power supply	4
serial communication	25	Demonstration Board	4
flow control	57	Dynamic C software	4
function calls		programming cable	4
ser485Rx	58	software	4
ser485Tx	58	User's Manual	4
serCflowcontrolOff	57	wire assembly	4
serCflowcontrolOn	57		
serMode	57	U	
programming port	27	user block	
RS-232 description	25	function calls	
RS-485 description	25	readUserBlock	36
RS-485 network	26	writeUserBlock	36
RS-485 termination and bias			
resistors	26		
serial ports			
Ethernet port	28		
setup	10		
power supply connections .	10		
software	5		
libraries	47		
BL2600	47		
BL26xx.LIB	47		
NAND flash	70		
PACKET.LIB	57		
RN_CFG_BL26.LIB	47		
RNET.LIB	98		
RS232.LIB	57		
TCP/IP	47		
NAND flash drivers	70		
sample programs	42		
PONG.C	14		
specifications			
BL2600			
electrical	79		
exclusion zone	80		
header footprint	81		
headers	81		
relative pin 1 locations ..	81		

